

AIR HOIST

**ENDO**





# WIRE ROPE TYPE

Wire rope series EHW / AH

## Type of hoisting

### EHW-60 , EHW-120

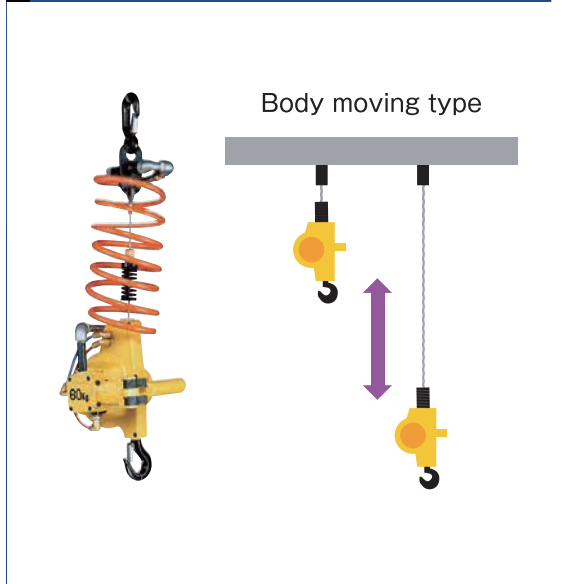

### EHW-60R , EHW-120R

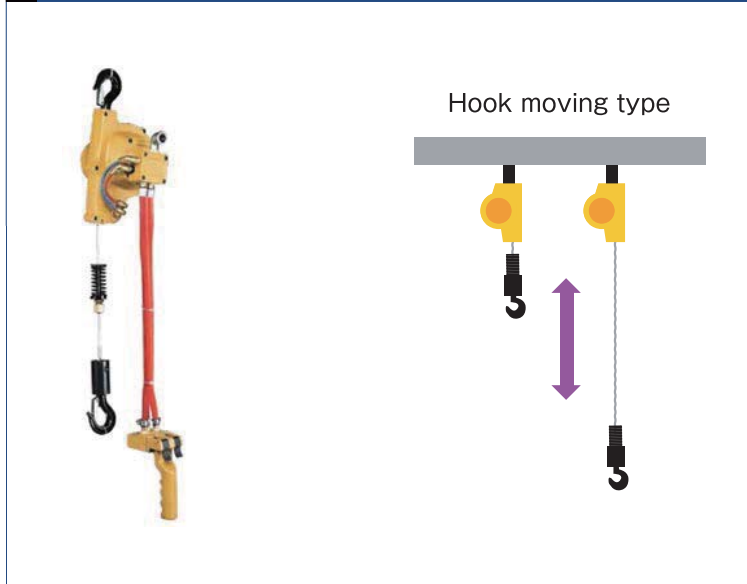

### EHW-60 , EHW-120

**FUNCTION**



Wire rope type



Button control



Plain trolley (on request)

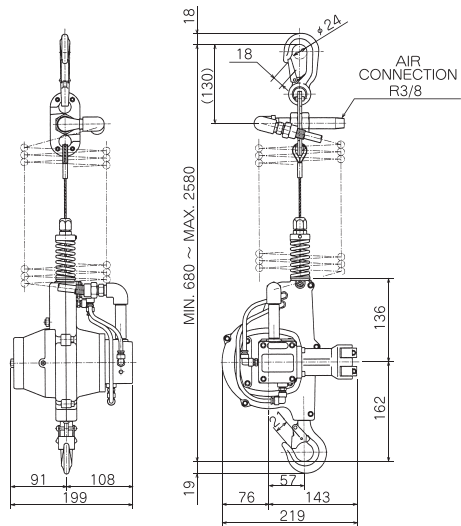

Model	Rated load (kg)	Stroke (m)	Air pressure MPa (kgf/cm <sup>2</sup> )	Lifting speed m/min	Air consumption m <sup>3</sup> /min (normal)	Air inlet	Mass (kg)
EHW-60	60	1.9	0.4 {4}	18.5	0.55	R 3/8	9.2
			0.5 {5}	22.5	0.7		
			0.6 {6}	26.0	0.88		
EHW-120	120		0.4 {4}	11.0	0.59		9.4
			0.5 {5}	13.5	0.75		
			0.6 {6}	16.0	0.93		

- Note**
1. Install a filter and lubricator to the hoist as close as possible.
  2. Both of cable extension and stroke extension are not available on EHW series and AH-250R.
  3. Chain hoists are recommended for the frequent operation.
  4. Application; Indoor -10°C~+50°C (Temperature)

## EHW-60R , EHW-120R

### FUNCTION



Wire rope type



Button control



Plain trolley (on request)



Emergency stop button (on request)

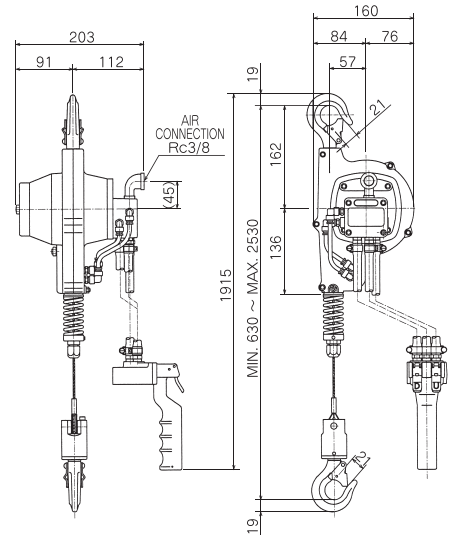

\*The Length of control hose is 1.5m.

Model	Rated load (kg)	Stroke (m)	Air pressure MPa (kgf/cm <sup>2</sup> )	Lifting speed m/min	Air consumption m <sup>3</sup> /min (normal)	Air inlet	Mass (kg)	
EHW-60R	60	1.9	0.4 {4}	18.5	0.55	Rc 3/8	9.5	
			0.5 {5}	22.5	0.7			
			0.6 {6}	26.0	0.88			
EHW-120R	120		0.4 {4}	11.0	0.59			9.7
			0.5 {5}	13.5	0.75			
			0.6 {6}	16.0	0.93			

**Note**

1. Install a filter and lubricator to the hoist as close as possible.
2. Both of cable extension and stroke extension are not available on EHW series and AH-250R.
3. Chain hoists are recommended for the frequent operation.
4. Application; Indoor -10°C~+50°C (Temperature)



# CHAIN TYPE

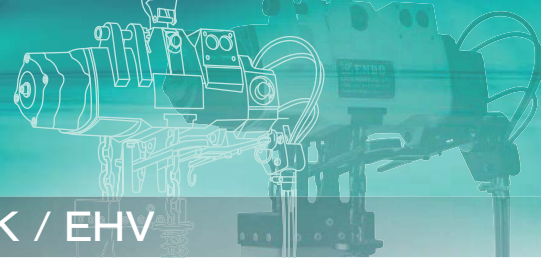

Load chain series AT / ATC / EHL / EHLK / EHV

ENDO chain hoists employ the surface hardened load chain with Grade DAT and provide long life and less maintenance cost.

## EHL series / select operation device

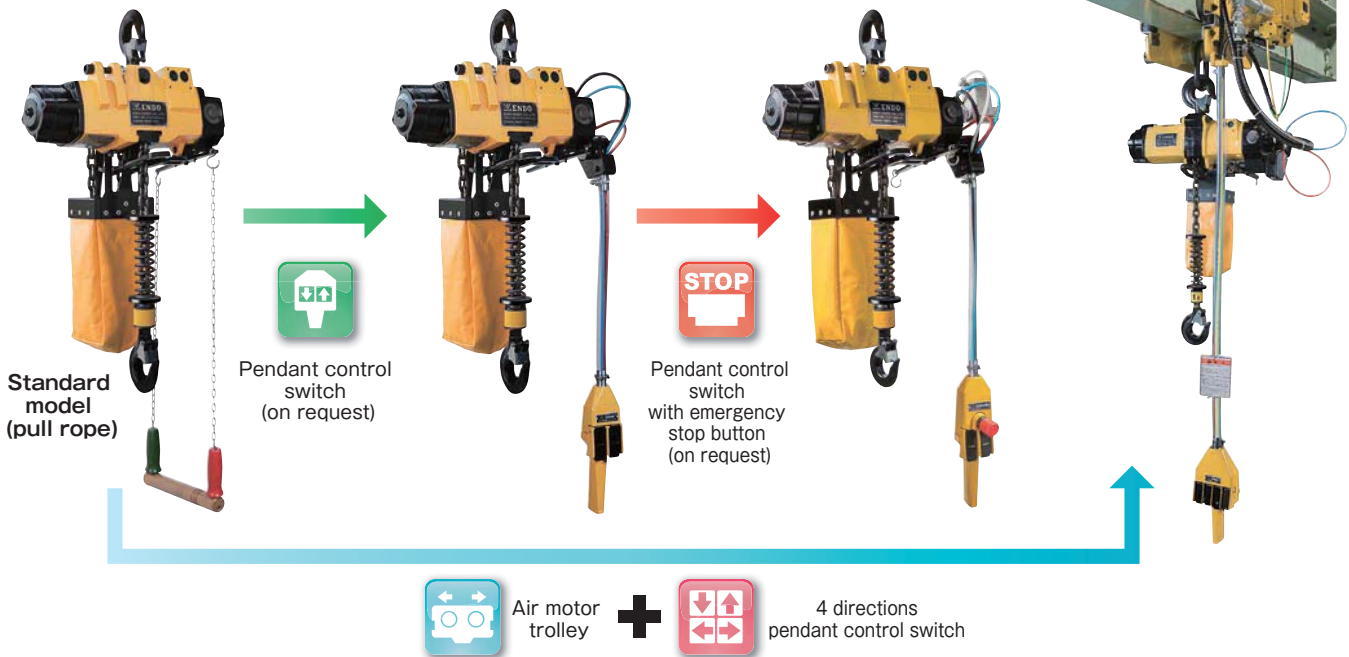

## AT-60K , AT-125K

### FUNCTION

- Chain type
- Button control
- Plain trolley (on request)
- Chain extension (on request)

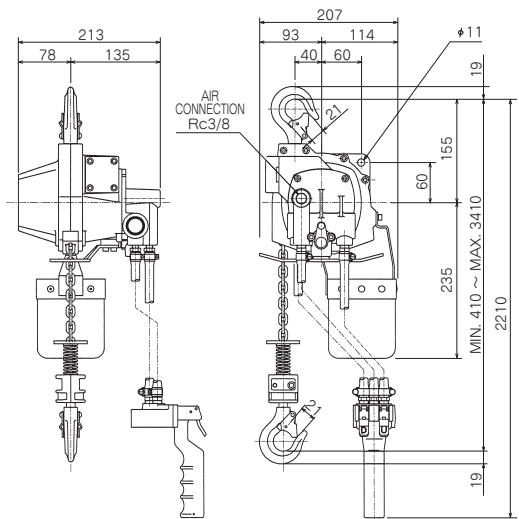

\*The Length of control hose is 1.8m.

Model	Rated load (kg)	Stroke (m)	Air pressure MPa {kgf/cm <sup>2</sup> }	Lifting speed m/min	Air consumption m <sup>3</sup> /min (normal)	Chain size × fall	Air inlet	Mass (kg)
AT-60K	60	3	0.4 {4}	16.5	0.52	4.0×1	Rc 3/8	12.3
			0.5 {5}	20.0	0.67			
			0.6 {6}	23.5	0.85			
AT-125K	125	3	0.4 {4}	10.0	0.55	4.0×1	Rc 3/8	12.5
			0.5 {5}	12.0	0.71			
			0.6 {6}	14.5	0.9			

**Note**

1. Install a filter and lubricator to the hoist as close as possible.
2. Application; Indoor -10°C~+50°C (Temperature)

## ATC-60K , ATC-125K

### FUNCTION



Chain type



Button control



Plain trolley (on request)

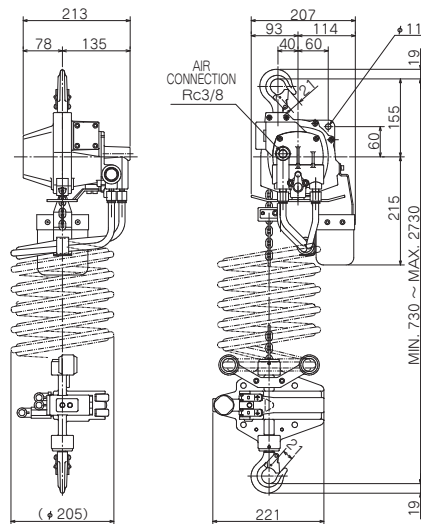

Model	Rated load (kg)	Stroke (m)	Air pressure MPa {kgf/cm <sup>2</sup> }	Lifting speed m/min	Air consumption m <sup>3</sup> /min (normal)	Chain size x fall	Air inlet	Mass (kg)
ATC-60K	60	2	0.4 {4}	14.0	0.45	4.0x1	Rc 3/8	14.3
			0.5 {5}	17.5	0.58			
			0.6 {6}	20.0	0.68			
ATC-125K	125		0.4 {4}	6.5	0.42			14.5
			0.5 {5}	10.5	0.55			
			0.6 {6}	12.0	0.65			

## AT-60K-5 , AT-125K-5 , ATC-60K-5 , ATC-125K-5

### FUNCTION



Chain type



Button control



Plain trolley (on request)



Emergency stop button



Chain extension (AT series)

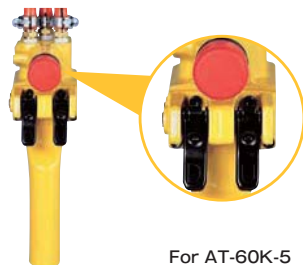

For AT-60K-5



For ATC-60K-5

\*The Length of control hose is 1.8m.

Model	Rated load (kg)	Stroke (m)	Air pressure MPa {kgf/cm <sup>2</sup> }	Lifting speed m/min	Air consumption m <sup>3</sup> /min (normal)	Chain size x fall	Air inlet	Mass (kg)
AT-60K-5	60	3	0.4 {4}	16.5	0.52	4.0x1	Rc 3/8	13.0
			0.5 {5}	20.0	0.67			
			0.6 {6}	23.5	0.85			
AT-125K-5	125		0.4 {4}	10.0	0.55			13.2
			0.5 {5}	12.0	0.71			
			0.6 {6}	14.5	0.9			
ATC-60K-5	60	2	0.4 {4}	14.0	0.45	14.3		
			0.5 {5}	17.5	0.58			
			0.6 {6}	20.0	0.68			
ATC-125K-5	125		0.4 {4}	6.5	0.42		14.5	
			0.5 {5}	10.5	0.55			
			0.6 {6}	12.0	0.65			

**Note**

1. Install a filter and lubricator to the hoist as close as possible.
2. Application; Indoor -10°C~+50°C (Temperature)



## EHL-05TS

### EHL-05TS

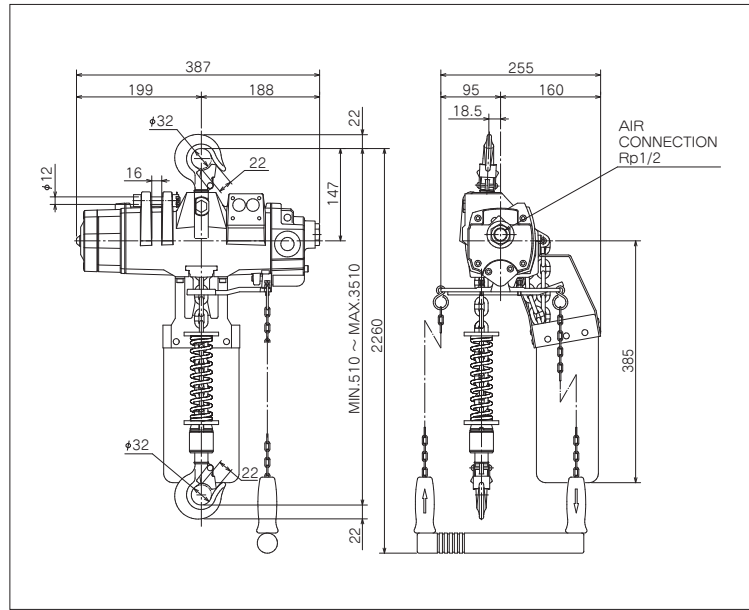

\*The length of control chain is 2m.

### EHL-05TS PCS-1

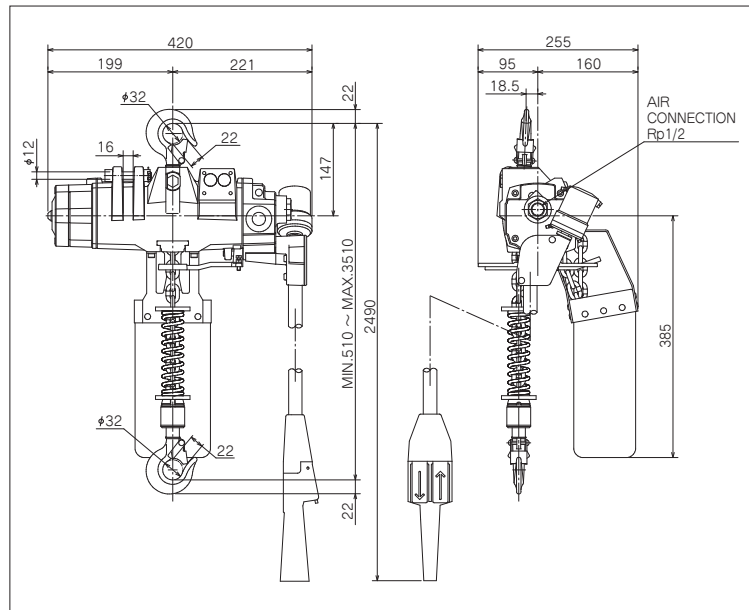

\*The Length of control tube is 2m.

## FUNCTION



Chain type



Pendant control switch (on request)



Chain extension (on request)



Air motor trolley (on request)



Overload protector (on request)

Model	Rated load (kg)	Stroke (m)	Air pressure MPa (kgf/cm <sup>2</sup> )	Lifting speed m/min	Air consumption m <sup>3</sup> /min (normal)	Chain size x fall	Air inlet	Mass (kg)
EHL-05TS	500	3	0.4 {4}	7.5	0.95	6.3x1	Rp 1/2	20.0
EHL-05TS PCS-1			0.5 {5}	9.0	1.3			22.0
			0.6 {6}	10.5	1.65			

Note) The extension of control tube is available up to 6m (total 8m length).

- Note**
1. Install a filter and lubricator to the hoist as close as possible.
  2. Application; Indoor -10°C~+50°C (Temperature)

EHL-1TW

EHL-1TW

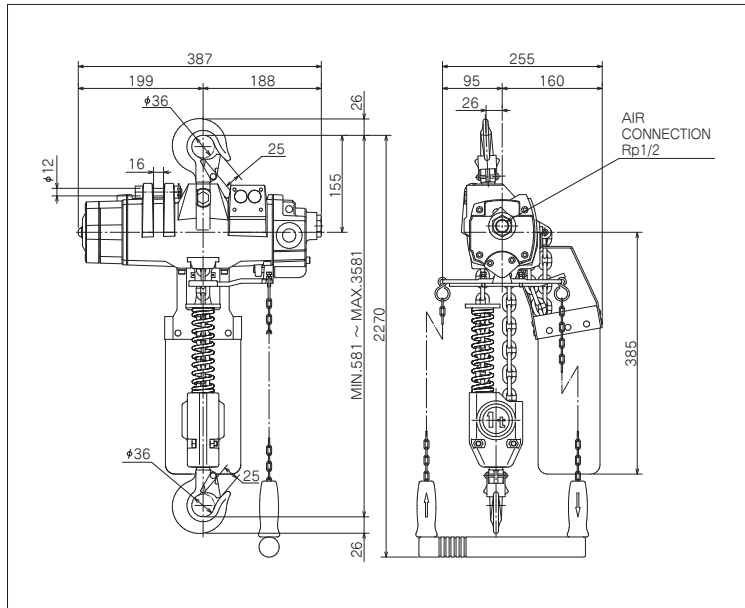

\*The length of control chain is 2m.

EHL-1TW PCS-1

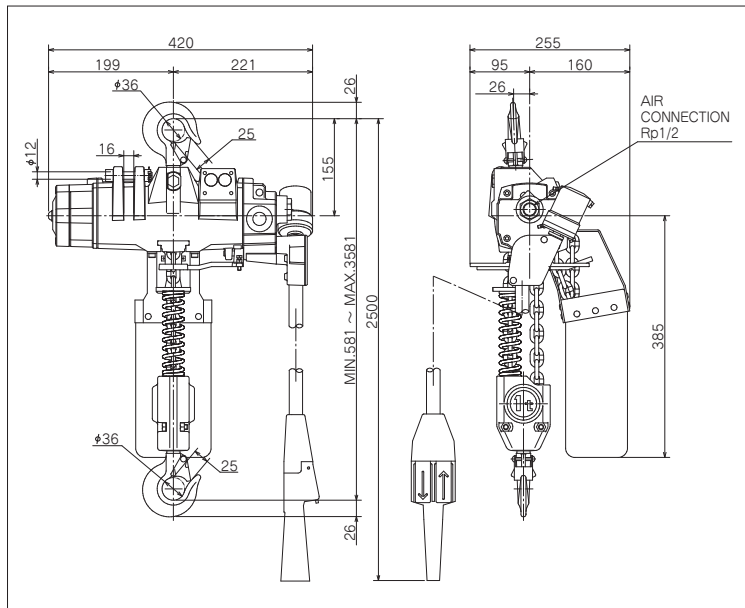
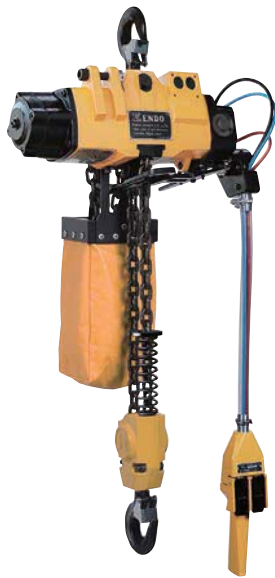

\*The Length of control tube is 2m.

FUNCTION



Chain type



Pendant control switch (on request)



Chain extension (on request)



Air motor trolley (on request)



Overload protector (on request)

Model	Rated load (t)	Stroke (m)	Air pressure MPa {kgf/cm <sup>2</sup> }	Lifting speed m/min	Air consumption m <sup>3</sup> /min (normal)	Chain size x fall	Air inlet	Mass (kg)
EHL-1TW	1	3	0.4 {4}	3.7	0.95	6.3x2	Rp 1/2	26.0
EHL-1TW PCS-1			0.5 {5}	4.5	1.3			28.0
			0.6 {6}	5.2	1.65			

Note) The extension of control tube is available up to 6m (total 8m length).

Note

1. Install a filter and lubricator to the hoist as close as possible.
2. Application; Indoor -10°C~+50°C (Temperature)



## EHL-1TS

### EHL-1TS

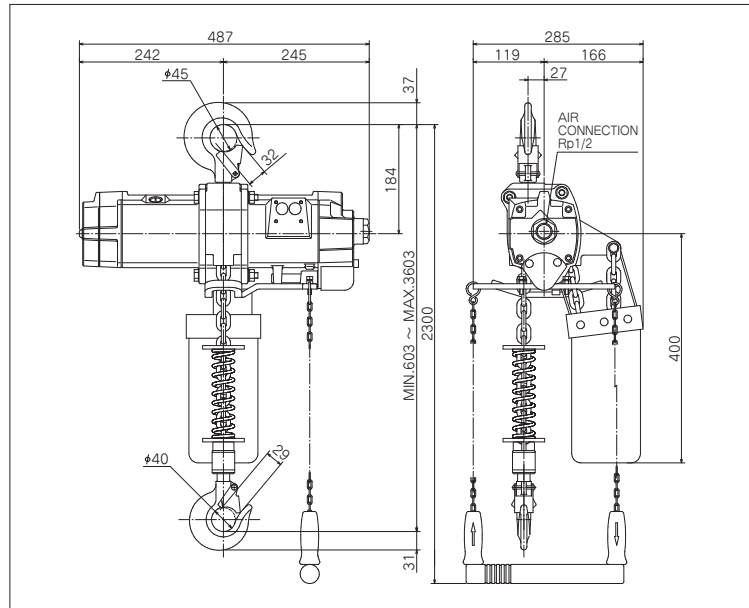

\*The length of control chain is 2m.

### EHL-1TS PCS-2

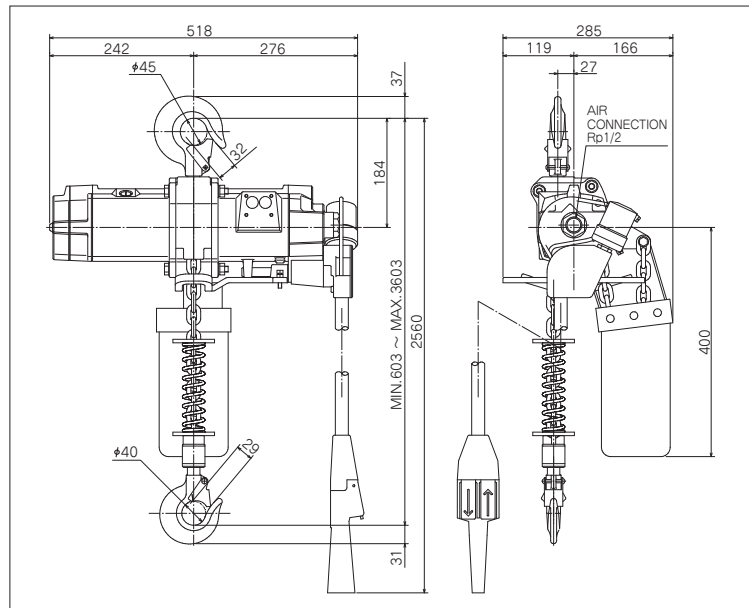
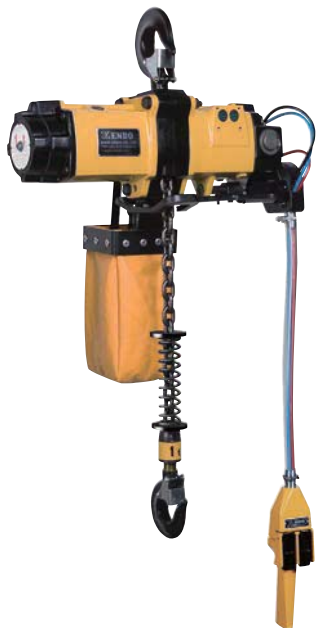

\*The Length of control tube is 2m.

## FUNCTION



Chain type



Pendant control switch (on request)



Emergency stop button (on request)



Chain extension (on request)



Air motor trolley (on request)



Overload protector (on request)

Model	Rated load (t)	Stroke (m)	Air pressure MPa (kgf/cm <sup>2</sup> )	Lifting speed m/min	Air consumption m <sup>3</sup> /min (normal)	Chain size x fall	Air inlet	Mass (kg)
EHL-1TS	1	3	0.4 {4}	4.0	1.0	7.1x1	Rp 1/2	34.0
EHL-1TS PCS-2			0.5 {5}	5.2	1.4			37.0
			0.6 {6}	6.0	1.8			

Note) The extension of control tube is available up to 6m (total 8m length).

- Note**
1. Install a filter and lubricator to the hoist as close as possible.
  2. Application; Indoor -10°C~+50°C (Temperature)

## EHL-2TW

### EHL-2TW

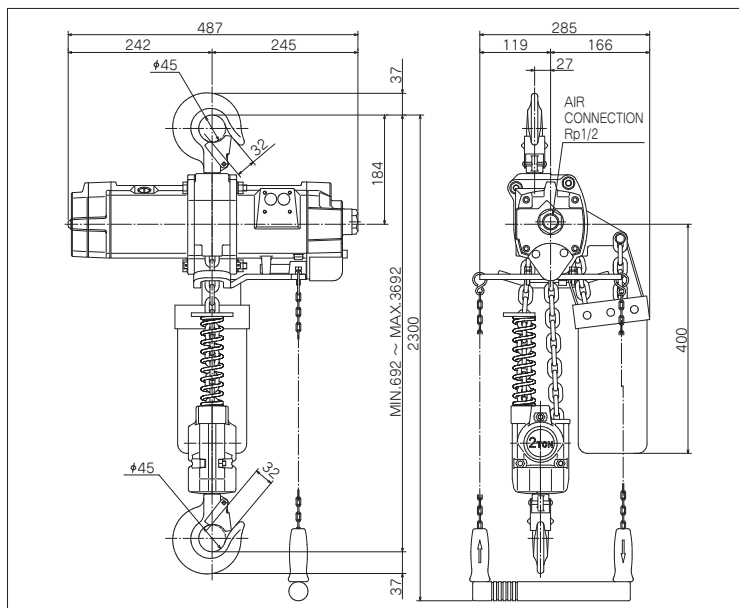

\*The length of control chain is 2m.

### EHL-2TW PCS-2

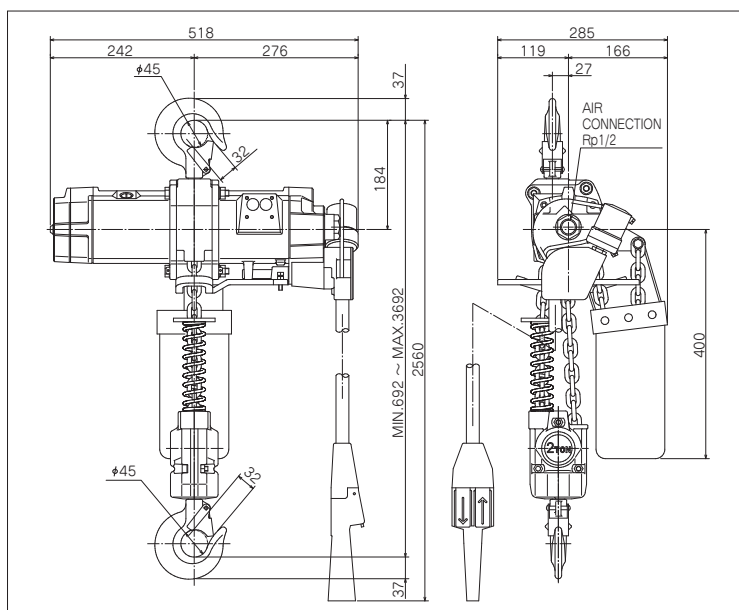
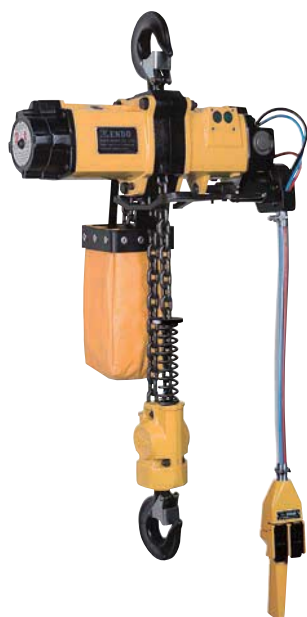

\*The Length of control tube is 2m.

### FUNCTION



Chain type



Pendant control switch (on request)



Emergency stop button (on request)



Chain extension (on request)



Air motor trolley (on request)



Overload protector (on request)

Model	Rated load (t)	Stroke (m)	Air pressure MPa {kgf/cm <sup>2</sup> }	Lifting speed m/min	Air consumption m <sup>3</sup> /min (normal)	Chain size × fall	Air inlet	Mass (kg)
EHL-2TW	2	3	0.4 {4}	2.0	1.0	7.1 × 2	Rp 1/2	42.0
EHL-2TW PCS-2			0.5 {5}	2.6	1.4			
			0.6 {6}	3.0	1.8			

Note) The extension of control tube is available up to 6m (total 8m length).

**Note**

1. Install a filter and lubricator to the hoist as close as possible.
2. Application; Indoor -10°C~+50°C (Temperature)

## EHL-3TS

### EHL-3TS

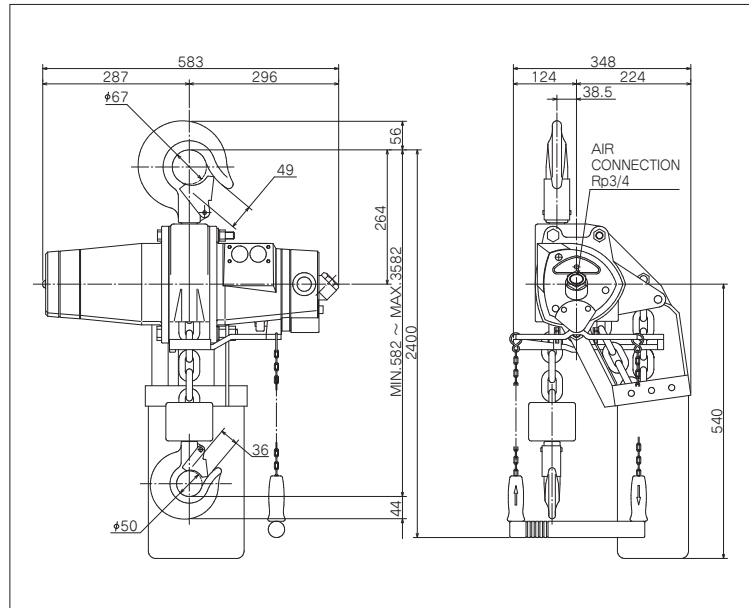

\*The length of control chain is 2m.

### EHL-3TS PCS-2

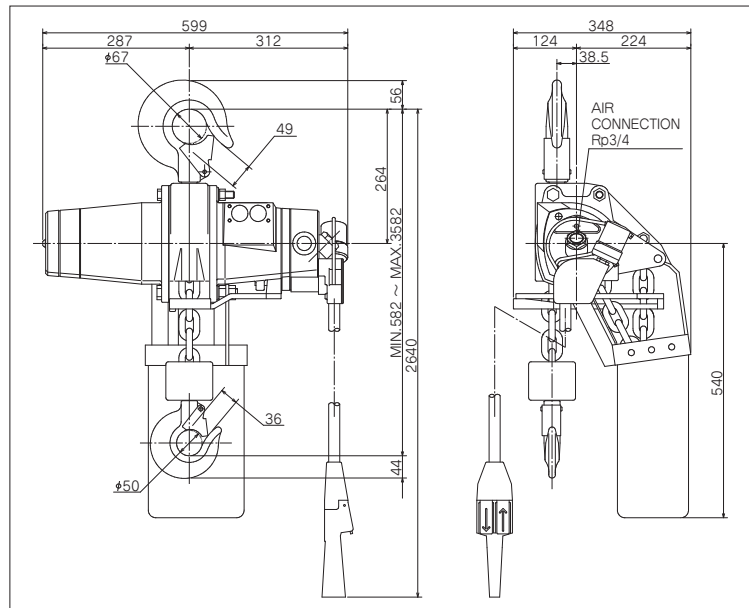

\*The Length of control tube is 2m.

## FUNCTION



Chain type



Pendant control switch (on request)



Emergency stop button (on request)



Chain extension (on request)



Air motor trolley (on request)



Overload protector (on request)

Model	Rated load (t)	Stroke (m)	Air pressure MPa (kgf/cm <sup>2</sup> )	Lifting speed m/min	Air consumption m <sup>3</sup> /min (normal)	Chain size x fall	Air inlet	Mass (kg)
EHL-3TS	3	3	0.4 {4}	2.0	1.75	12.5x1	Rp 3/4	79.0
EHL-3TS PCS-2			0.5 {5}	2.6	2.47			81.0
			0.6 {6}	3.0	3.14			

Note) The extension of control tube is available up to 6m (total 8m length).

**Note**

1. Install a filter and lubricator to the hoist as close as possible.
2. Application; Indoor -10°C~+50°C (Temperature)

## EHL-6TW

### EHL-6TW

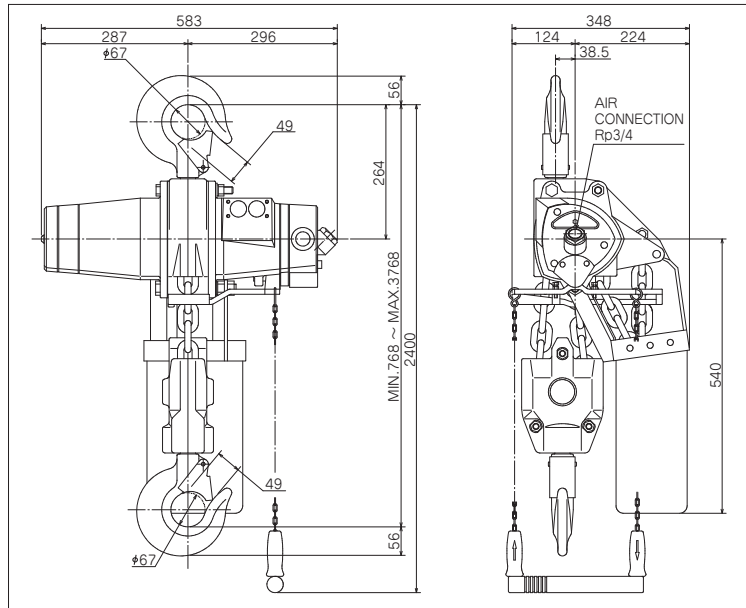

\*The length of control chain is 2m.

### EHL-6TW PCS-2

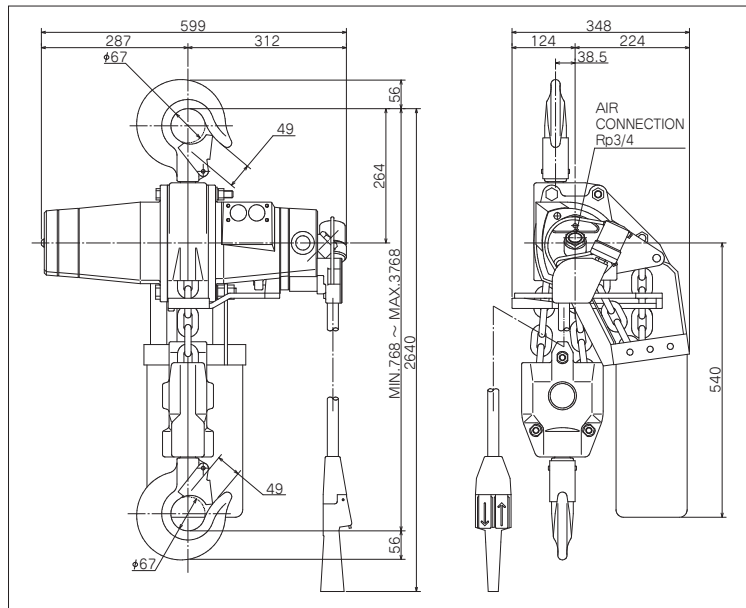

\*The Length of control tube is 2m.

## FUNCTION



Chain type



Pendant control switch (on request)



Emergency stop button (on request)



Chain extension (on request)



Air motor trolley (on request)



Overload protector (on request)

Model	Rated load (t)	Stroke (m)	Air pressure MPa {kgf/cm <sup>2</sup> }	Lifting speed m/min	Air consumption m <sup>3</sup> /min (normal)	Chain size × fall	Air inlet	Mass (kg)
EHL-6TW	6	3	0.4 {4}	1.0	1.75	12.5×2	Rp 3/4	101.0
EHL-6TW PCS-2			0.5 {5}	1.3	2.47			103.0
			0.6 {6}	1.5	3.14			

Note) The extension of control tube is available up to 6m (total 8m length).

**Note**

1. Install a filter and lubricator to the hoist as close as possible.
2. Application; Indoor -10°C~+50°C (Temperature)

## EHLK-1TS , EHLK-2TW

### EHLK-1TS

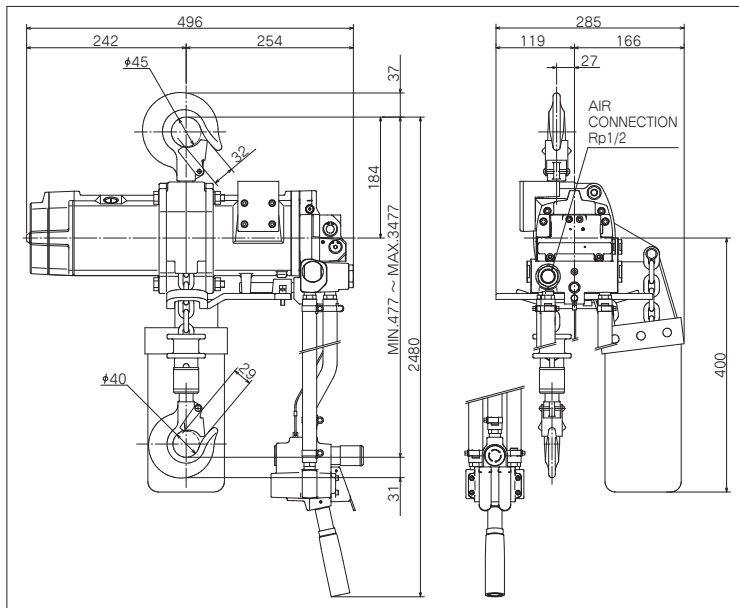

\*The Length of control tube is 2m.

### EHLK-2TW

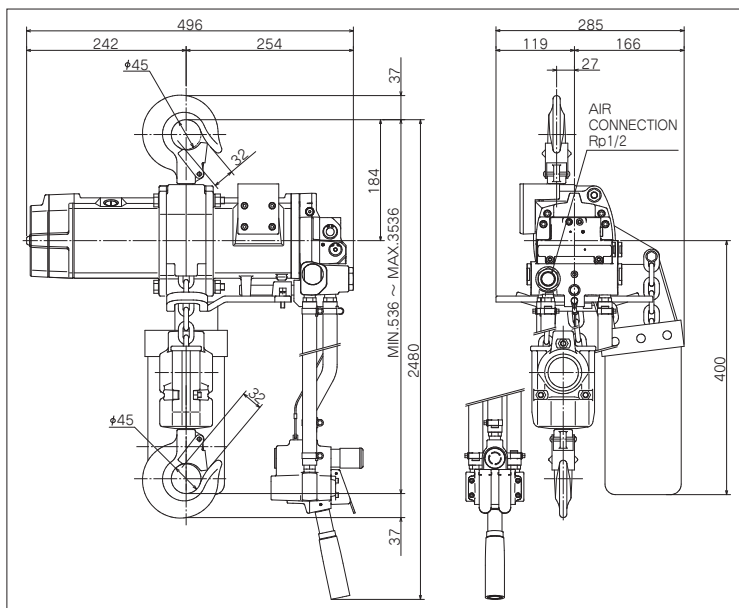

\*The Length of control tube is 2m.

### FUNCTION



Chain type



Button control



Emergency stop button



Built-in overload protector



Chain extension (on request)

Model	Rated load (t)	Stroke (m)	Air pressure MPa (kgf/cm <sup>2</sup> )	Lifting speed m/min	Air consumption m <sup>3</sup> /min (normal)	Chain size x fall	Air inlet	Mass (kg)
EHLK-1TS	1	3	0.4 {4}	3.3	1.3	7.1x1	Rp 1/2	38.0
			0.5 {5}	4.3	1.4			
			0.6 {6}	5.3	1.5			
EHLK-2TW	2		0.4 {4}	1.6	1.3	7.1x2		46.0
			0.5 {5}	2.1	1.4			
			0.6 {6}	2.6	1.5			

Note) The extension of control tube is available up to 6m (total 8m length).

**Note**

1. Install a filter and lubricator to the hoist as close as possible.
2. Application; Indoor -10°C~+50°C (Temperature)

## EHV25SP , EHV50SP

### EHV25SP

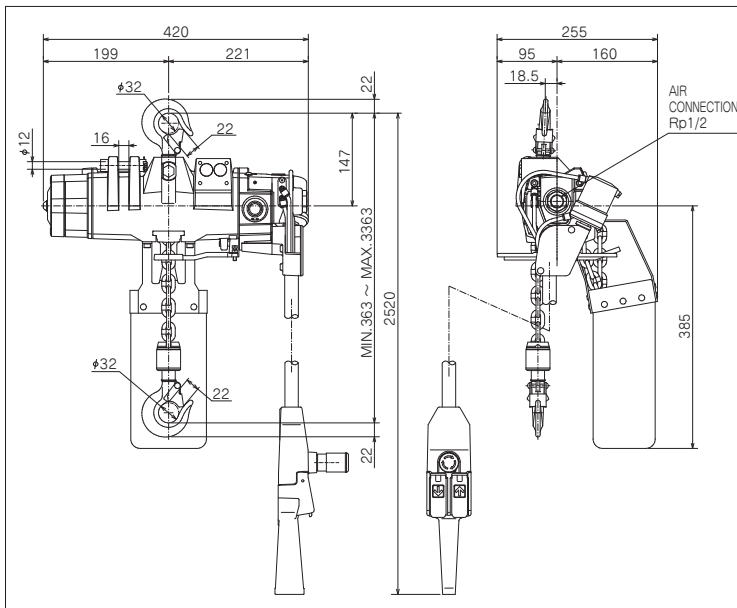

\*The Length of control tube is 2m.

### EHV50SP

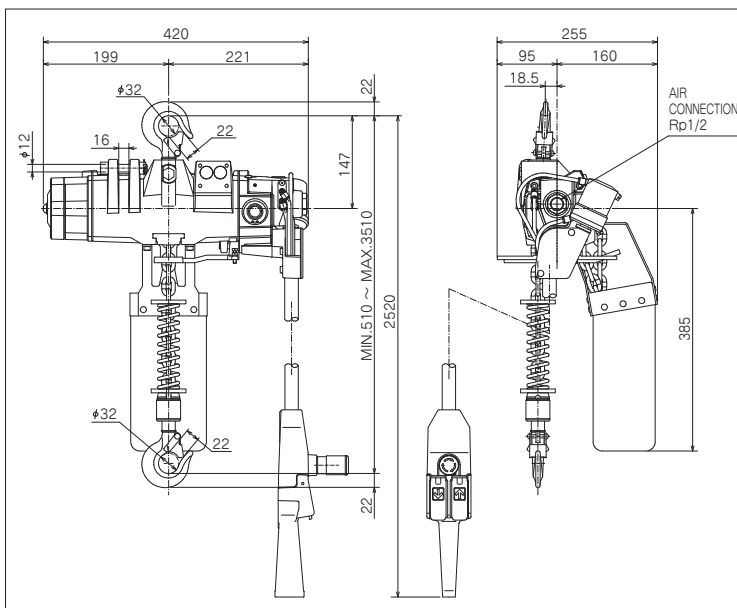

\*The Length of control tube is 2m.

### FUNCTION



Chain type



Button control



Emergency stop button



Chain extension (on request)



Air motor trolley (on request)



Overload protector (on request)

Model	Rated load (kg)	Stroke (m)	Air pressure MPa {kgf/cm <sup>2</sup> }	Lifting speed m/min	Air consumption m <sup>3</sup> /min (normal)	Chain size x fall	Air inlet	Mass (kg)
EHV25SP	250	3	0.4 {4}	12.0	0.9	6.3x1	Rp 1/2	23.0
			0.5 {5}	16.0	1.3			
			0.6 {6}	18.0	1.6			
EHV50SP	500		0.4 {4}	7.5	0.95			
			0.5 {5}	9.0	1.3			
			0.6 {6}	10.5	1.65			

Note) The extension of control tube is available up to 6m (total 8m length).

**Note**

1. Install a filter and lubricator to the hoist as close as possible.
2. Application; Indoor -10°C~+50°C (Temperature)

EHV100WP

EHV100WP

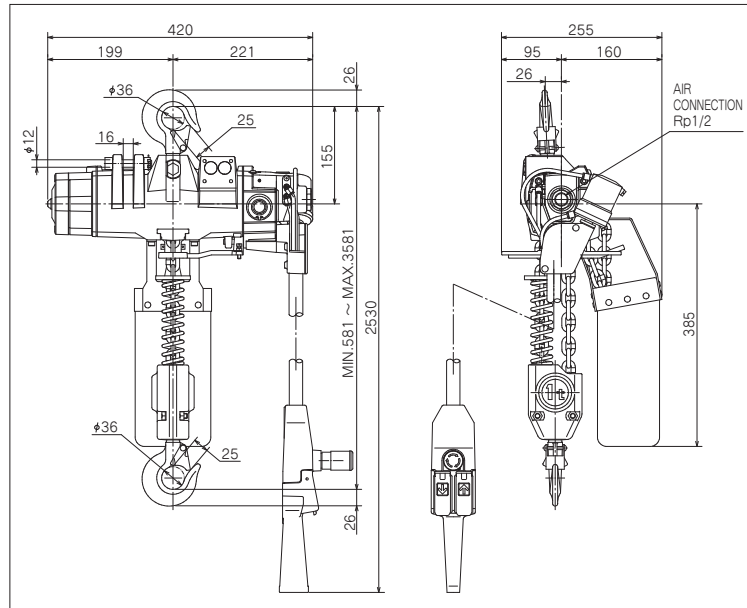

\*The Length of control tube is 2m.

FUNCTION



Chain type



Button control



Emergency stop button



Chain extension (on request)



Air motor trolley (on request)



Overload protector (on request)

Model	Rated load (kg)	Stroke (m)	Air pressure MPa (kgf/cm <sup>2</sup> )	Lifting speed m/min	Air consumption m <sup>3</sup> /min (normal)	Chain size x fall	Air inlet	Mass (kg)
EHV100WP	1000	3	0.4 {4}	3.7	0.95	6.3x2	Rp 1/2	29.0
			0.5 {5}	4.5	1.3			
			0.6 {6}	5.2	1.65			

Note) The extension of control tube is available up to 6m (total 8m length).

- Note**
1. Install a filter and lubricator to the hoist as close as possible.
  2. Application; Indoor -10°C~+50°C (Temperature)

Explosion proof for Air hoists (ATEX)

ATEX approved models are as the following list.

Air hoists which require ATEX approval must be ordered together with "Required accessories for ATEX" on the list. The air hoists comply with ATEX only in the EU region.

ATEX class:  $\text{Ex}$  II3GD Ex h IIB T4 Gc  
Ex h IIB T135°C Dc

Pull rope control		Pendant switch control	
Model	Required accessories for ATEX	Model	Required accessories for ATEX
EHV25SC*1	-	EHV25SP	-
EHV50SC*1	-	EHV50SP	-
EHV100WC-OP*1*2	-	EHV100WP-OP*2	-
EHL-1TS	Overload protector OP-1TS	EHL-1TS	1. Overload protector OP-1TS 2. Pendant switch PCS-2BV1
EHL-2TW	Overload protector OP-2TW	EHL-2TW	1. Overload protector OP-2TW 2. Pendant switch PCS-2BV1
EHL-3TS	Overload protector OP-3TS	EHL-3TS	1. Overload protector OP-3TS 2. Pendant switch PCS-2BV2
EHL-6TW	Overload protector OP-6TW	EHL-6TW	1. Overload protector OP-6TW 2. Pendant switch PCS-2BV2

\*1 The pull rope control type corresponded with EHV25SP, EHV50SP and EHV100WP. Specifications are same as each model except dimensions and mass.

\*2 Included overload protector.



# AIR MOTOR TROLLEY

## Air motor trolley - MTH series -

**ENDO trolleys are ideal for hazardous locations, such as a chemical factory because the power source is not electricity, but compressed air.**

**The unit uses stepless speed controls for precise and efficient operation.**



EHL-1TS  
with MTH-2T-5  
PCS-42

### Pendant control switch

Model	Air motor trolley	Mass (kg)
PCS-41	MTH-1T-5+EHL-025TS/05TS/1TW	3.2
PCS-41BV	MTH-1T-5+EHL-025TS/05TS/1TW EHV25SP/49SP/50SP/100WP	3.7
PCS-42	MTH-2T-5+EHL-1TS/2TW, MTH-6.3T+EHL-3TS/6TW	3.6
PCS-42BV	MTH-2T-5+EHL-1TS/2TW, MTH-6.3T+EHL-3TS/6TW	4.4

Note) "BV" indicates "Emergency stop button equipped".

\*The extension of control tube is available up to 5.6m (total 8m length).

### Specification

Model	Rated load (t)	Air pressure MPa {kgf/cm <sup>2</sup> }	Travelling speed m/min	Air consumption m <sup>3</sup> /min (normal)	Available rail width (mm)	Min.radius for curve (mm)	Air inlet	Mass (kg)
MTH-1T-5	1	0.4 {4}	20	0.55	75	3500	Rc 1/2	35.0
		0.5 {5}	25	0.6				
		0.6 {6}	28	0.65	100 · 125	800		
MTH-2T-5	2	0.4 {4}	16	1.05	125 · 150	1000	Rc 1/2	63.0
		0.5 {5}	17	1.3				
		0.6 {6}	18	1.6				
MTH-6.3T	6.3	0.4 {4}	17	1.05	150·175·190	2500	Rc 3/4	127.0
		0.5 {5}	18	1.3				
		0.6 {6}	19	1.6				

Note) Four push buttons control (4 directions) is available as well as two push buttons control (2 directions). It depends on the customer request. Low head room application is available on request.

### Corresponding Table - Air hoist / Air motor trolley -

Model	EHL-025TS	EHL-05TS	EHL-098TW	EHL-1TW	EHL-1TS	EHL-2TW	EHL-3TS	EHL-6TW	EHV25SP	EHV49SP	EHV50SP	EHV100WP
MTH-1T-5	○	○	○	○					○	○	○	○
MTH-2T-5					○	○						
MTH-6.3T							○	○				



**ENDO AIR HOIST MTH SERIES**

**MTH-1T-5 PCS-41**

**FUNCTION**



4 directions  
pendant control  
**PCS-41**  
**PCS-41BV**



Emergency  
stop button  
(on request)

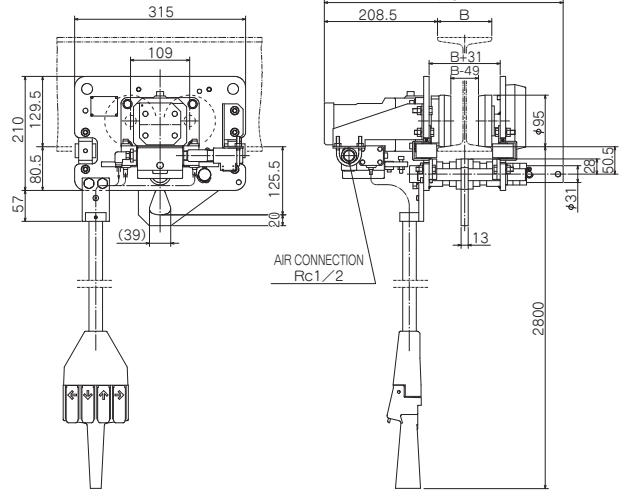

\*The Length of control tube is 2.4m.

**MTH-2T-5 PCS-42**

**FUNCTION**



4 directions  
pendant control  
**PCS-42**  
**PCS-42BV**



Emergency  
stop button  
(on request)

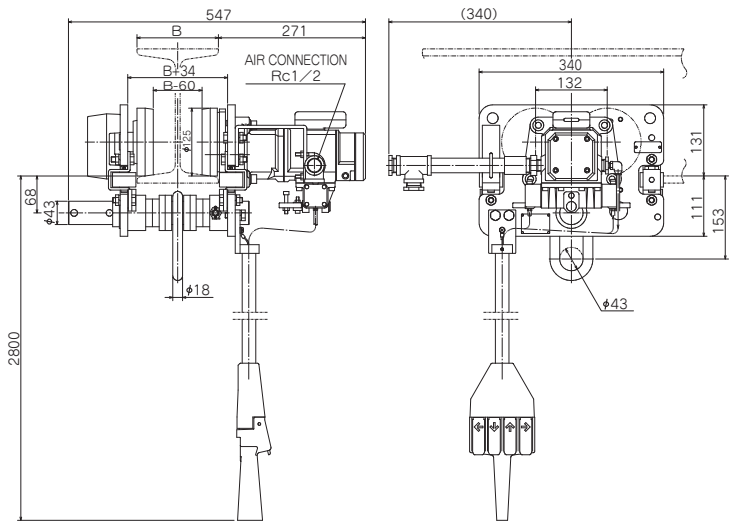

\*The Length of control tube is 2.4m.

**MTH-6.3T PCS-42**

**FUNCTION**



4 directions  
pendant control  
**PCS-42**  
**PCS-42BV**



Emergency  
stop button  
(on request)

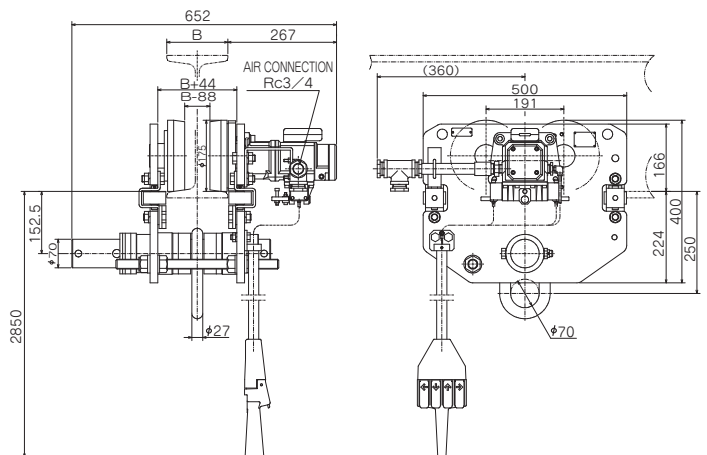

\*The Length of control tube is 2.4m.

**Note**

1. Install a filter and lubricator to the hoist as close as possible.
2. Application; Indoor -10°C~+50°C (Temperature)

## Accessories

### Cleaner set



This device is available for eliminating noisy volume and gathering the exhausted oil from the exhaust hole. The device contributes to clean environment.

Parts Number	Air hoist		Mass (kg)
LHP001343	EHL-025TS	EHL-049TS	1.0
	EHL-05TS	EHL-1TW	
	EHV25SP	EHV49SP	
LHP001388	EHL-1TS	EHL-2TW	1.0
LHP001389	EHL-3TS	EHL-6TW	1.6

### Overload protector

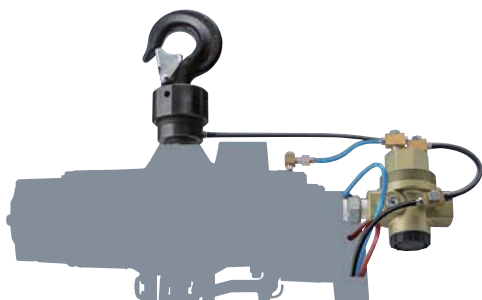

This device stops the operation automatically when it exceeds the rated load.

Air hoist		Mass (kg)
EHL-05TS	EHV50SP	2.0
EHL-1TW	EHV100WP	2.2
EHL-1TS		6.2
EHL-2TW		6.2
EHL-3TS		22.0
EHL-6TW		22.0

### Pendant control switch PCS-1 / PCS-2

Optional pendant controls are available to replace the standard pull rope.

Model	Air hoist		Mass (kg)
PCS-1	EHL-025TS	EHL-049TS	2.3
	EHL-05TS	EHL-1TW	
PCS-2	EHL-1TS	EHL-2TW	2.7
	EHL-3TS	EHL-6TW	
PCS-2BV1	EHL-1TS	EHL-2TW	3.2
PCS-2BV2	EHL-3TS	EHL-6TW	3.5



Note) 1. Max. control tube extension is up to 6m (total length of hose must be less than 8m).  
2. EHV has the pendant control switch including emergency stop button as standard.

## Options

### Stainless steel load chain

Due to the lower breaking load of the stainless steel chain, the loading capacity of EHL-1TS and 2TW would be reduced to 80% of the rated capacity. For 3 tons and 6 tons hoist, no stainless chain is available.

### Chain buckets

ENDO supplies a chain bucket for the undermentioned chain lengths.

Model / chain lengths	6m	10m	12m	20m
AT-60K / AT-125K	○		△	△
EHL-025TS / EHL-05TS / EHL-1TW	○		△	△
EHV25SP / EHV49SP / EHV50SP / EHV100WP	○		△	△
EHL-1TS / EHL-2TW	○		△	△
EHL-3TS / EHL-6TW	○	△		

Note) 1. ○ mark means a standard bucket.  
2. △ mark means an optional bucket.  
3. When you need the bucket capable of the other chain lengths, contact our distributors or ENDO.

# Specification

## Wire rope series EHW / AH

Model	Rated load (kg)	Stroke (m)	Air pressure MPa {kgf/cm <sup>2</sup> }	Lifting speed m/min	Air consumption m <sup>3</sup> /min (normal)	Air inlet	Mass (kg)
EHW-60	60	1.9	0.4 {4}	18.5	0.55	R 3/8	9.2
			0.5 {5}	22.5	0.7		
			0.6 {6}	26.0	0.88		
EHW-60R	60	1.9	0.4 {4}	18.5	0.55	Rc 3/8	9.5
			0.5 {5}	22.5	0.7		
			0.6 {6}	26.0	0.88		
EHW-120	120	1.9	0.4 {4}	11.0	0.59	R 3/8	9.4
			0.5 {5}	13.5	0.75		
			0.6 {6}	16.0	0.93		
EHW-120R	120	1.9	0.4 {4}	11.0	0.59	Rc 3/8	9.7
			0.5 {5}	13.5	0.75		
			0.6 {6}	16.0	0.93		
AH-250R	160	2.5	0.4 {4}	9.0	0.75	Rc 1/2	18.2
	200		0.5 {5}	10.0	0.92		
	250		0.6 {6}	11.0	1.1		

(Note) Application; Indoor -10°C~+50°C(Temperature)

## Load chain series AT / ATC / EHL / EHLK / EHV

Model	Rated load (t)	Stroke (m)	Air pressure MPa {kgf/cm <sup>2</sup> }	Lifting speed m/min	Air consumption m <sup>3</sup> /min (normal)	Chain size×fall	Air inlet	Mass (kg)
AT-60K AT-60K-5	60kg	3	0.4 {4}	16.5	0.52	4.0×1	Rc 3/8	12.3 (13.0)
			0.5 {5}	20.0	0.67			
			0.6 {6}	23.5	0.85			
ATC-60K ATC-60K-5	60kg	2	0.4 {4}	14.0	0.52	4.0×1	Rc 3/8	14.3
			0.5 {5}	17.5	0.67			
			0.6 {6}	20.0	0.85			
AT-125K AT-125K-5	125kg	3	0.4 {4}	10.0	0.55	4.0×1	Rc 3/8	12.5 (13.2)
			0.5 {5}	12.0	0.71			
			0.6 {6}	14.5	0.9			
ATC-125K ATC-125K-5	125kg	2	0.4 {4}	6.5	0.42	4.0×1	Rc 3/8	14.5
			0.5 {5}	10.5	0.55			
			0.6 {6}	12.0	0.65			
EHL-025TS	250kg	3	0.4 {4}	12.0	0.9	6.3×1	Rp 1/2	20.0
			0.5 {5}	16.0	1.3			
			0.6 {6}	18.0	1.6			
EHL-049TS	490kg	3	0.4 {4}	7.5	0.95	6.3×1	Rp 1/2	20.0
			0.5 {5}	9.0	1.3			
			0.6 {6}	10.5	1.65			
EHL-05TS	500kg	3	0.4 {4}	7.5	0.95	6.3×1	Rp 1/2	20.0
			0.5 {5}	9.0	1.3			
			0.6 {6}	10.5	1.65			
EHL-1TW	1	3	0.4 {4}	3.7	0.95	6.3×2	Rp 1/2	26.0
			0.5 {5}	4.5	1.3			
			0.6 {6}	5.2	1.65			
EHL-1TS	1	3	0.4 {4}	4.0	1.0	7.1×1	Rp 1/2	34.0
			0.5 {5}	5.2	1.4			
			0.6 {6}	6.0	1.8			
EHL-2TW	2	3	0.4 {4}	2.0	1.0	7.1×2	Rp 1/2	42.0
			0.5 {5}	2.6	1.4			
			0.6 {6}	3.0	1.8			
EHL-3TS	3	3	0.4 {4}	2.0	1.75	12.5×1	Rp 3/4	79.0
			0.5 {5}	2.6	2.47			
			0.6 {6}	3.0	3.14			
EHL-6TW	6	3	0.4 {4}	1.0	1.75	12.5×2	Rp 3/4	101.0
			0.5 {5}	1.3	2.47			
			0.6 {6}	1.5	3.14			
EHLK-1TS	1	3	0.4 {4}	3.3	1.3	7.1×1	Rp 1/2	38.0
			0.5 {5}	4.3	1.4			
			0.6 {6}	5.3	1.5			
EHLK-2TW	2	3	0.4 {4}	1.6	1.3	7.1×2	Rp 1/2	46.0
			0.5 {5}	2.1	1.4			
			0.6 {6}	2.6	1.5			
EHV25SP	250kg	3	0.4 {4}	12.0	0.9	6.3×1	Rp 1/2	23.0
			0.5 {5}	16.0	1.3			
			0.6 {6}	18.0	1.6			
EHV49SP	490kg	3	0.4 {4}	7.5	0.95	6.3×1	Rp 1/2	23.0
			0.5 {5}	9.0	1.3			
			0.6 {6}	10.5	1.65			
EHV50SP	500kg	3	0.4 {4}	7.5	0.95	6.3×1	Rp 1/2	23.0
			0.5 {5}	9.0	1.3			
			0.6 {6}	10.5	1.65			
EHV100WP	1	3	0.4 {4}	3.7	0.95	6.3×2	Rp 1/2	29.0
			0.5 {5}	4.5	1.3			
			0.6 {6}	5.2	1.65			

(Note) ENDO air hoists are available for only indoor,with temperature of -10°C~+50°C.The figures( )indicate AT-60K-5 and AT-125K-5.



## **AIR HOIST**

### **ENDO** ENDO KOGYO CO., LTD.

3-14-7, Akibacho, Tsubame, Niigata, Japan  
TEL : +81-256-62-5131 FAX.+81-256-62-5772

<http://www.endo-kogyo.co.jp>



ISO9001 JP97/010458  
SCOPE : Head office, Plant



ISO14001 JP10/070952  
SCOPE : Head office, Plant

### **ENDO** ENDO KOGYO INDIA PVT. LTD.

101, First Floor, Aditya Towers  
LullaNagar, Off Kondhwa Road, Pune - 411 040  
TEL : +91-86-00042752 Mail.[info@endo-india.co.in](mailto:info@endo-india.co.in)

<http://www.endo-india.co.in>

