



PROFESSIONAL TORQUE TOOLS

A professional torque wrench is shown diagonally across the page. The handle is on the left, featuring a large black dial and several adjustment buttons. The shaft extends towards the top right. The background is split into a light grey upper half and a blue lower half.

**MANUFACTURERS OF
TORQUE TESTERS,
CALIBRATION EQUIPMENT,
ELECTRONIC & MECHANICAL
TORQUE TOOLS**

**2013 FULL LINE
PRODUCT CATALOG**

THE MOST RESPECTED NAME IN TORQUE TOOLS, TESTERS AND CALIBRATION EQUIPMENT.

CDI was founded in 1968 and over the years has developed into a world class torque products manufacturing company. The company earned its ISO 9001 International Quality System Certification in 1998, demonstrating a commitment to provide our customers with the highest quality torque measurement and torque limiting devices in the world. Today, the CDI Brand is now part of Snap-on Specialty Tools, a member of the Snap-on Incorporated family of companies. Snap-on Specialty Tools manufactures products for other Snap-on businesses and select OEM and industrial customers world-wide.

CDI is a primary supplier of torque wrenches and torque screwdrivers to the GSA (General Service Administration of the U.S. Government) since 1968. All CDI products are individually serialized and meet or exceed appropriate ASME and ISO standards. CDI's mechanical torque product lines include click type torque wrenches, dial indicating torque wrenches, torque limiting screwdrivers, calibration equipment and a number of special application torque products. CDI has long been a major innovator and leader in electronic torque measurement and torque calibration equipment.

All Snap-on Specialty Tools employees recognize the importance of our customers' satisfaction with our products and services. We have a full time Product Development Team dedicated to develop and deliver innovative new torque products.

Thank you for providing us the opportunity to serve you.



ELECTRONIC

MULTITEST Torque, Force & Tension Calibration System	2
MULTITEST Motorized System.....	5
SURETEST Torque Calibration System	6
MULTITEST/SURETEST Accessories	9
CALIBRATION EQUIPMENT.....	11
DTT Digital Torque Tester	14
MULTITORQ Torque and Data Collection System	16
COMPUTORQ II Electronic Torque Wrench	17
COMPUTORQ3 Electronic Torque Wrench.....	18
COMPUTORQ3 Electronic Torque and Angle Wrench.....	19
COMPUTORQ3 Heavy Duty 3/4" Torque and Angle Wrench.....	20
ELECTRONIC DIAL TORQUE WRENCHES	21

MECHANICAL

TORQUE SCREWDRIVERS Micro Adjustable.....	22
TORQUE SCREWDRIVERS Pre-Set	23
TORKY™ Pre-Set Wrench	23
TORQUE WRENCHES Dial Indicating Type	24
TORQUE WRENCHES Micro-Adjustable.....	27
TORQUE WRENCHES Split Beam Quick Set.....	30
TORQUE ACCESSORIES	31
TORQUE WRENCHES Adjustable Interchangeable	32
TORQUE WRENCHES Pre-Set Interchangeable.....	32
INTERCHANGEABLE HEADS	33

INFORMATION

TORQUE FACTS.....	40
REPAIR AND SERVICE CENTER	42
WARRANTY POLICY.....	42
INDEX	43
WARRANTY STATIONS	Inside back cover

MULTITEST CALIBRATION SYSTEMS

The **MULTITEST Torque, Force and Tension Calibration System** is the most sophisticated system available in the industry. This system will test and calibrate most types of torque wrenches, torque screwdrivers, torque multipliers, cable tensiometers, tension and compression gauges and non-impact power tools such as nutrunners and electric screwdrivers.

The Multitest Calibration System can be ordered several ways. Each system begins with the same three basic components: the Multitest Digital Monitor, the Roller Cabinet and the 2000 ft. lb. Mechanical Loader. We offer three different systems, the "Premier", the "Supreme" and the "Basic". These systems and their components are described in detail on the next few pages.

In addition, you may order any component separately to build your own "custom" system.

Features

- Automatic sensor recognition with "smart" transducers
- Range: 5 in. oz. to 2000 ft. lb. torque (bi-directional)
- Accuracy: $\pm 0.25\%$ of indicated value, cw & ccw, from 10% to 100% of full scale, (except 2000-4-02")
- Built-in, low profile serial printer
- Date and time stamp for stored values
- Statistical analysis performed on stored data
- Stores up to 3000 torque values
- Programmable manual or automatic options for clear, store and print functions
- 110 or 220 Volts selectable. Foreign plugs are included
- Recall and review of stored torque values
- Track, peak, first peak, power tool modes
- RS232C port, analog output
- Eight torque measurement units:
in. oz., in. lb., ft. lb., Nm, dNm, cNm, mkg and cmkg
- Six force units: ounce, pound, newton, deciNewton, kilopound (kilogram) and gram
- Automatic lock-up for transducer protection
- All transducers supplied with certification
- Individually serialized with matching certificate of calibration traceable to N.I.S.T.



Multitest Digital Monitor with Soft Touch Keys.





MULTITEST PREMIER CALIBRATION SYSTEM

CDI's All Inclusive Calibration System Model 2000-1

Features

- Our most comprehensive calibration system for torque and force
- Calibrate torque wrenches up to 2000 ft. lbs.
- Check the accuracy and calibrate cable tensiometers, tension and compression gauges
- Includes the easy-to-use 4-in-1 transducer kit
- Eleven single transducers ranging from 5 in. oz. up to 2000 ft. lbs.
- Includes torque screwdriver testing kit
- Automatic safety feature locks system to prevent overloading and possible damage to transducers
- Displays eight units of torque and six units of force
- Also includes a calibration stand and all necessary calibration wheels, arms, weights and trays
- Downloading software included

MODEL 2000-1 INCLUDES:

Product Code	Description	Product Code	Description
2000-610-02	MULTITEST Monitor	2000-550-02	Extension Arm Kit for Long Torque Wrenches
2000-600-02	Mechanical Loader 2000 ft. lb. capacity	2000-750-02	Torque Screwdriver Testing Kit
2000-100-02	Roller Cabinet	2000-320-0	No. 1 Weight Set
2000-400-02	4 in 1 Transducer Kit, 4 in. lbs. to 250 ft. lbs.	2500-50-0	2-1/2" Calibration Wheel
2000-500-02	4 In 1 Transducer Adapter Kit	2000-151-0	5" Calibration Wheel
2000-4-02*	Transducer Range From 5 - 50 in. ozs. ($\pm 0.5\%$)	2000-152-0	10" Butterfly Wheel
2000-5-02	Transducer Range From 15 - 200 in. ozs.	2000-154-0	40" Calibration Arm
2000-6-02	Transducer Range From 4 - 50 in. lbs.	390-2-2	4 oz. Weight Hanger
2000-65-02	Transducer Range From 15 - 150 in. lbs.	2000-301	8 oz. Weight Hanger
2000-7-02	Transducer Range From 30 - 400 in. lbs.	2000-304-0	7.5 lb. Weight Hanger
2000-8-02	Transducer Range From 80 - 1000 in. lbs.	2000-302-0	15 lb. Weight Hanger
2000-10-02	Transducer Range From 10 - 125 ft. lbs.	2000-303-0	50 lb. Weight Hanger
2000-11-02	Transducer Range From 20 - 250 ft. lbs.	2000-250-02	Calibration Stand Kit
2000-12-02	Transducer Range From 60 - 600 ft. lbs.	2000-260-0	Cable Tension Meter Testing Kit
2000-13-02	Transducer Range From 100 - 1000 ft. lbs.	2000-261-0	Tension Force Gauge Testing Kit
2000-14-02	Transducer Range From 200 - 2000 ft. lbs.	2000-262-0	Compression Force Gauge Testing Kit
900-0-1KIT	Joint Rate Simulator 50 in. lbs. capacity	2000-263-02	Force Arm Kit
900-2-01KIT	Joint Rate Simulator 400 in. lbs. capacity	2000-SW	PC Software
900-3-01KIT	Joint Rate Simulator 1000 in. lbs. capacity	2000-50-1	Cable from MULTITEST to PC



4 in 1 Transducer Kit with Mounting Adapter



MULTITEST SUPREME CALIBRATION SYSTEM

CDI's Torque-Only System Model 2000-2. Listed below are all of the components to CDI's "Supreme" MULTITEST Torque Calibration System. This is our mid-range system for torque, which has a range from 15 in. ozs. to 2000 ft. lbs. Designed for the user who requires precision accuracy and reliability in a torque calibration system. This set includes an extension arm for long torque wrenches and 3 joint rate simulators for testing power tools. (Not for use with impact and pulse tools.) PC compatible software and cables are also included.

MODEL 2000-2 INCLUDES:

Product Code	Description
2000-610-02	Multitest Digital Monitor
2000-600-02	Mechanical Loader Max 2000 ft.lb.
2000-100-02	Roller / Storage Cabinet 45" W x 24" D x 33" H
2000-400-02	4 in 1 Transducer Kit-Range 4 in. lb. to 250 ft. lb.
2000-500-02	4 in 1 Transducer Adapter Kit
2000-4-02	Transducer Kit-Range 5-50 in. oz.
2000-5-02	Transducer Kit-Range 15-200 in. oz.
2000-12-02	Transducer Kit-Range 60-600 ft. lb.
2000-13-02	Transducer Kit-Range 100-1000 ft. lb.
2000-14-02	Transducer Kit-Range 200-2000 ft. lb.
2000-550-02	Extension Arm for Long Torque Wrench, Reach up to 80"
900-0-1KIT	1/4" drive, 50 in. lb. Capacity Joint Rate Simulator
900-2-01KIT	3/8" drive, 400 in. lb. Capacity Joint Rate Simulator
900-3-01KIT	3/8" drive, 1000 in. lb. Capacity Joint Rate Simulator
2000-SW	Wedglink Software
2000-50-1	Cable from MULTITEST or SURETEST to PC



4 in 1 Transducer Kit with Mounting Adapter.

MULTITEST BASIC CALIBRATION SYSTEM

Listed below are all of the components to CDI's "Basic" MULTITEST Calibration System Model 2000-3. The system includes the 4 in 1 transducer, which is capable of calibrating torque tools from 4 in. lbs. through 250 ft. lbs. Also included is the 2000 ft. lb. loader and the MULTITEST monitor.

MODEL 2000-3 INCLUDES:

Product Code	Description
2000-610-02	Multitest Digital Monitor
2000-600-02	Mechanical Loader Max 2000 ft.lb.
2000-100-02	Roller / Storage Cabinet 45" W x 24" D x 33" H
2000-400-02	4 in 1 Transducer Kit-Range 4 in. lb. to 250 ft. lb.
2000-500-02	4 in 1 Transducer Adapter Kit





MULTITEST MOTORIZED SYSTEM

CDI has taken torque calibration to a higher level. Increase your productivity with the 2000 ft. lb. fully automatic motorized loader. Designed for the high volume calibration laboratory that requires a high-speed, automatic torque calibration system. In the automatic mode, the **MULTITEST Motorized System Model 2800-1** will cycle, test and calibrate most torque wrenches. With our optional kits, you can calibrate torque screwdrivers, cable tensiometers, tension and compression gauges utilizing the manual mode, (hand crank only).

The MULTITEST Motorized System consists of the Monitor, Motorized Loader, Roller Cabinet and Extension Arm. Please order the transducers separately based on your individual needs. (Not for use with impact and pulse tools.)

Features

- Automatic sensor recognition with "smart" transducers
- Range: 5 in. oz. to 2000 ft. lb. torque (bi-directional)
- Accuracy: $\pm 0.25\%$ of indicated value, CW & CCW, from 10% to 100% of full scale
- Dual mode function (manual & automatic)
- Automatic speed control
- Built-in, low profile serial printer
- Date and time stamp for stored values
- Statistical analysis performed on stored data
- Emergency stop button
- Programmable manual or automatic options for clear, store and print functions
- Recall and review of stored torque values
- Track, peak, first peak, power tool modes
- RS232C port, analog output
- Eight torque measurement units: in. oz., in. lb., ft. lb., Nm, dNm, cNm, mkg and cmkg
- Six force units: ounce, pound, newton, deciNewton, kilopound and gram
- Automatic lock-up for transducer protection
- All transducers are individually serialized with matching certificate of calibration traceable to N.I.S.T.

MODEL 2800-1 INCLUDES:

Product Code	Description
2000-810-01	MULTITEST Digital Monitor
2000-800-02	Motorized Loader with roller cabinet
2000-550-02	Extension Arm for Long Torque Wrench, Reach up to 80"

Note: Transducers not included, order separately as required.



Dual Mode Function Manual and Automatic

SURETEST PREMIER CALIBRATION SYSTEM

The **SURETEST Model 5000-1** is a laboratory grade instrument which captures torque measurements with a user friendly interface. It features a large LCD graphical display. It may be used with a single transducer or can be used as the principal component of a Torque Calibration System.

The SURETEST features versatile data acquisition capabilities including measurement storage, retrieval, statistical analysis and automatic downloading to an external printer/ computer. The SURETEST stores, recalls and downloads up to 3000 torque readings. The system provides readings with an accuracy of $\pm .25\%$ of indicated value and features multiple languages: English, Spanish, French, Japanese and German.

The SURETEST Torque Calibration System may be ordered in three different combinations. The "Premier", the "Supreme" and the "Basic" systems are described on these pages. In addition, you may order any component separately to build your own "custom" system.

Features

- Large LCD graphical display
- Five built-in languages
- Date and time stamp
- Dual RS-232 ports, analog output
- SPC built-in
- Automatic downloading
- Accuracy: $\pm 0.25\%$ of indicated value, CW & CCW, from 10% to 100% of full scale
- Transducers available from 5 in. ozs. to 2000 ft. lbs. of torque
- All transducers are "smart" (plug and play)
- Readout in eight different engineering units
- Stores and recalls 5000 torque values (date & time)
- Fully automatic voltage input adaptation (100 - 240 VAC input)
- Data is saved when SURETEST is turned off
- All transducers are individually serialized with matching certificate of calibration traceable to N.I.S.T.



Set-up is quick and easy utilizing soft touch keys.

MODEL 5000-1 INCLUDES:

Product Code	Description	Product Code	Description
5000-ST	Suretest Monitor w/Cable and Case	2000-320-0	Weight Set #1
2000-600-02	Mechanical Loader Max 2000 ft.lb.	2500-50-0	2 1/2" Calibration Wheel
2000-100-02	Roller / Storage Cabinet 45" W x 24" D x 33" H	2000-151-0	5" Calibration Wheel
2000-400-02	4 in 1 Transducer Kit-Range 4 in. lb. to 250 ft. lb.	2000-152-0	10" Butterfly Calibration Wheel
2000-500-02	4 in 1 Transducer Adapter Kit	2000-154-0	40" Calibration Arm
2000-4-02	Transducer Kit-Range 5-50 in. oz.	390-2-2	4 oz. Hanger Calibration Weight Tray
2000-5-02	Transducer Kit-Range 15-200 in. oz.	2000-301	8 oz. Hanger Calibration Weight Tray
2000-12-02	Transducer Kit-Range 60-600 ft. lb.	2000-304-0	7.5 lb. Calibration Weight Tray
2000-13-02	Transducer Kit-Range 100-1000 ft. lb.	2000-302-0	15 lb. Calibration Weight Tray
2000-14-02	Transducer Kit-Range 200-2000 ft. lb.	2000-303-0	50 lb. Calibration Weight Tray
2000-550-02	Extension Arm for Long Torque Wrench, Reach up to 80"	2000-250-02	Calibration Stand Kit
900-0-1KIT	1/4" drive, 50 in. lb. Capacity Joint Rate Simulator	2000-SW	Wedglink Software
900-2-01KIT	3/8" drive, 400 in. lb. Capacity Joint Rate Simulator	2000-50-1	Cable from MULTITEST or SURETEST to PC
900-3-01KIT	3/2" drive, 1000 in. lb. Capacity Joint Rate Simulator		
2000-750-02	Torque Screwdriver Testing Kit for 2000-600-02 Loader		



Easy, quick change transducers.





SURETEST SUPREME CALIBRATION SYSTEM

CDI's Mid-Range Torque System Model 5000-2. Listed below are all of the components to CDI's "Supreme" SURETEST Torque Calibration System. This mid-range torque system has a range from 5 in. ozs. to 2000 ft. lbs. Choose SURETEST for unsurpassed accuracy and reliability in a torque calibration system. Also includes an extension arm for long torque wrenches and 3 joint rate simulators for testing power tools. (Not for use with impact and pulse tools.) PC compatible software and cables are included.

MODEL 5000-2 INCLUDES:

Product Code	Description
5000-ST	Suretest Monitor w/Cable and Case
2000-600-02	Mechanical Loader Max 2000 ft.lb.
2000-100-02	Roller / Storage Cabinet 45" W x 24" D x 33" H
2000-400-02	4 in 1 Transducer Kit-Range 4 in. lb. to 250 ft. lb.
2000-500-02	4 in 1 Transducer Adapter Kit
2000-4-02	Transducer Kit-Range 5-50 in. oz.
2000-5-02	Transducer Kit-Range 15-200 in. oz.
2000-12-02	Transducer Kit-Range 60-600 ft. lb.
2000-13-02	Transducer Kit-Range 100-1000 ft. lb.
2000-14-02	Transducer Kit-Range 200-2000 ft. lb.
2000-550-02	Extension Arm for Long Torque Wrench, Reach up to 80"
900-0-1KIT	1/4" drive, 50 in. lb. Capacity Joint Rate Simulator
900-2-01KIT	3/8" drive, 400 in. lb. Capacity Joint Rate Simulator
900-3-01KIT	3/8" drive, 1000 in. lb. Capacity Joint Rate Simulator
2000-SW	Wedglink Software
2000-50-1	Cable from MULTITEST or SURETEST to PC



Set-up is quick and easy utilizing soft touch keys



4 in 1 Transducer Slides Easily into Adapter Kit



Telescoping Arm extends to accommodate 600 ft. lbs. wrenches



Quick Release Pins make changing transducers a snap

SURETEST™ BASIC CALIBRATION SYSTEM

The **SURETEST Model 5000-3** is a laboratory grade instrument which captures torque measurements with a user friendly interface. It features a large LCD graphical display. It may be used with a single transducer or can be used as the principal component of a Torque Calibration System.

The SURETEST features versatile data acquisition capabilities including measurement storage, retrieval, statistical analysis and automatic downloading to an external printer/computer. The SURETEST stores, recalls and downloads up to 3000 torque readings. The system provides readings with an accuracy of +/- .25% of indicated value and features multiple languages: English, Spanish, French, Japanese and German.

Features

- Large LCD graphical display
- Five built-in languages
- Date and time stamp
- Dual RS-232 ports, analog output
- SPC built-in
- Automatic downloading
- Accuracy is +/- 0.25% of indicated value, CW & CCW, from 10% to 100% of full scale
- Transducers available from 5 in. ozs. to 2000 ft. lbs. of torque
- All transducers are "Smart" (Plug and Play)
- Readout in eight different engineering units
- Stores and recalls 3000 torque values (Date & Time)
- Fully automatic voltage input adaptation (100 - 240 VAC input)
- Data is saved when SURETEST is turned off
- All transducers supplied with certification
- All transducers are individually serialized with matching certificate of calibration traceable to N.I.S.T.



MODEL 5000-3 INCLUDES:

Product Code	Description
5000-ST	Suretest Monitor w/Cable and Case
600TL-2	Mechanical Loader 600 ft. lb.
2000-400-02	4 in 1 Transducer Kit-Range 4 in. lb. to 250 ft. lb.
2000-500-02	4 in 1 Transducer Adapter Kit
2000-12-02	Transducer Kit-Range 60-600 ft. lb.



4 in 1 Transducer Kit with Mounting Adapter.

CUSTOM CALIBRATION SYSTEMS

Don't see the exact system you're looking for? Please call customer service to request a quotation on a custom calibration system. We will provide assistance designing a testing system to fit your application and specifications.



Female by Female socket adapters are used in a variety of torque testing and torque calibration applications.



4 in 1 Transducer 2000-400-02



Adapter Kit 2000-500-02



Transducer 2000-14-02



Transducer 2000-6-02

MULTITEST/SURETEST ACCESSORIES

Build Your Own Torque Calibration System.

Product Code	Description
2000-610-02	MULTITEST Monitor

5000-ST	SURETEST Monitor
---------	------------------

Product Code	Description
2000-600-02	Mechanical Loader, 2000 ft. lbs.

600TL-2	Mechanical Loader, 600 ft. lbs.
---------	---------------------------------

Socket Adapters Female X Female

Product Code	Opening	X	Opening
260-27	1/4" hex	X	1/4" sq.
342-40	1/4" sq.	X	1/4" sq.
342-41-1	1/4" sq.	X	3/8" sq.
342-41-2	3/8" sq.	X	3/8" sq.
65-26-2	1/2" sq.	X	3/8" sq.
65-26-3	1/2" sq.	X	1/2" sq.
65-78-1	1/2" sq.	X	3/4" sq.
65-78-2	3/4" sq.	X	3/4" sq.
75-25-1	1 sq.	X	3/4" sq.
75-20	1 sq.	X	1" sq.

Product Code	Description
2000-100-02	Roller Cabinet

Product Code	Description	
2000-400-02	4 in 1 Transducer	(Shown)
2000-500-02	4 in 1 Transducer Adapter Kit	(Shown)
2000-4-02	Transducer Range 5 - 50 in. ozs.	(Not Shown)
2000-5-02	Transducer Range 15 - 200 in. ozs.	(Not Shown)
2000-6-02	Transducer Range 4 - 50 in. lbs.	(Shown)
2000-65-02	Transducer Range 15 - 150 in. lbs.	(Not Shown)
2000-7-02	Transducer Range 30 - 400 in. lbs.	(Not Shown)
2000-8-02	Transducer Range 80 - 1000 in. lbs.	(Not Shown)
2000-10-02	Transducer Range 10 - 125 ft. lbs.	(Not Shown)
2000-11-02	Transducer Range 20 - 250 ft. lbs.	(Not Shown)
2000-12-02	Transducer Range 60 - 600 ft. lbs.	(Not Shown)
2000-13-02	Transducer Range 100 - 1000 ft. lbs.	(Not Shown)
2000-14-02	Transducer Range 200 - 2000 ft. lbs.	(Shown)



MULTITEST/SURETEST ACCESSORIES

Build Your Own Torque Calibration System.

Product Code Description

2000-550-02 Extension Arm Kit for Long Torque Wrenches
(For Torque Wrenches over 45 inches long)



Product Code Description

900-0-1KIT Joint Rate Simulator 50 in. lbs. capacity (Not Shown)
900-2-01KIT Joint Rate Simulator 400 in. lbs. capacity (Shown)
900-3-01KIT Joint Rate Simulator 1000 in. lbs. capacity (Not Shown)



Product Code Description

2000-750-02 Torque Screwdriver Testing Kit for 2000-600-2
2000-750-06 Torque Screwdriver Testing Kit for 600TL-2 (Not Shown)



Product Code Description

2000-260-0 Cable Tension Meter Testing Kit
(Tensiometer, Force Arms not included)



Product Code Description

2000-261-0 Tension Force Gauge Testing Kit
(Tension Gauge, Force Arms not included)



Product Code Description

2000-262-0 Compression Force Gauge Testing Kit
(Compression Gauge, Force Arms not included)



Product Code Description

2000-263-02 Force Arm Kit
(Only one required for any testing kit)



Product Code Description

2000-50-1 Cable from MULTITEST/SURETEST to PC



Product Code Description

2000-50-2 Cable from MULTITEST/SURETEST to external serial printer



Product Code Description

2000-SW PC Software



CALIBRATION EQUIPMENT

CDI's **calibration equipment** is expressly designed to calibrate the complete line of CDI Torque Transducers. All weight trays, arms and brackets supplied by CDI Torque Products are built with precision accuracy to meet the demanding needs of the calibration professional. All calibration wheels and arms are certified as to length, and supplied with a certificate of accuracy, which is traceable to N.I.S.T. (National Institute of Standards and Technology). Weights, trays and hangers are weight certified and are also supplied with a certificate of accuracy traceable to N.I.S.T. Mass Classification is Class F. Mating adapters are available to facilitate the use of the various components. Written procedures are available upon request for calibrating any of CDI's manufactured torque products.



Product Code	Description
2000-250-02	Calibration Stand Kit



Transducer mounting adapters included with stand.



Product Code	Description
390-2-2	4 oz. Weight Hanger
2000-301	8 oz. Weight Hanger
2000-304-0	7.5 lb. Weight Hanger
2000-302-0	15 lb. Weight Hanger
2000-303-0	50 lb. Weight Hanger

Weight Sets Itemized

Product Code	Description	Qty
2000-320-0	Weight Set #1 (not shown)	
Consists of the following:		
	50 lb. Block Weight	8
	20 lb. Block Weight	5
	10 lb. Block Weight	4
	5 lb. Slotted Weight	6
	2 lb. Slotted Weight	4
	1 lb. Slotted Weight	2
	½ lb. Slotted Weight	1
	4 oz. Slotted Weight	1
	2 oz. Slotted Weight	1

(For All Transducers)



Product Code	Description	Qty
2000-321-0	Weight Set #2 (not shown)	
Consists of the following:		
	50 lb. Block Weight	4
	20 lb. Block Weight	4
	10 lb. Block Weight	4
	5 lb. Slotted Weight	6
	2 lb. Slotted Weight	4
	1 lb. Slotted Weight	2
	½ lb. Slotted Weight	1
	4 oz. Slotted Weight	1
	2 oz. Slotted Weight	1

(For 200 in. oz. to 600 ft. lbs.)

Product Code	Description	Qty
2000-322-0	Weight Set #3 (not shown)	
Consists of the following:		
	50 lb. Block Weight	8
	20 lb. Block Weight	5
	10 lb. Block Weight	4
	5 lb. Slotted Weight	2
	2 lb. Slotted Weight	1
	1 lb. Slotted Weight	1

(For 600 ft. lbs. to 2000 ft. lbs.)

Note: Weights not sold separately

CALIBRATION EQUIPMENT

Product Code	Description
2000-152-3	1/2" x 3/8" Sq. Drive Reducer
2000-226-3	3/4" x 1/2" Sq. Drive Reducer
2000-226-2	1" x 3/4" Sq. Drive Reducer
2000-0154-18	1 1/4" x 3/4" Sq. Drive Reducer (for 600 ft. lbs. transducer)
S/2000-221-0	1 1/4" Flange Adapter
2344-0051-02	3/8" X 3/8" M X M Sq. Dr. Adaptors
2344-0051-11	1/4" X 1/4" M X M Sq. Dr. Adaptors
2344-0051-16	3/8" X 1/2" M X M Sq. Dr. Adaptors
2344-0051-13	1/2" X 1/2" M X M Sq. Dr. Adaptors
2344-0051-19	3/4" X 1-1/4" M X M Sq. Dr. Adaptors

Product Code	Description
2500-50-0	2 1/2" Calibration Wheel, 1/4" Dr.
2000-151-0	5" Calibration Wheel, 1/4" Dr.
2000-152-0	10" Butterfly Wheel, 1/2" Dr. (Includes 3/8" drive adapter)
2000-154-0	40" Calibration Arm, 1 1/4" Dr. (Includes 3/4" drive adapter)

Product Code	Description
342-35	Transducer Bracket, 5-1000 in. lbs.
342-36	Transducer Bracket, 125-600 ft. lbs.
343-25	Transducer Bracket, 4 in 1 / ETT
2000-150-03	Transducer Bracket, 1000-2000 ft. lbs.

Product Code	Description
2344-0050-03	Table Mounting Bracket for DTT Series Testers

Product Code	Description
900-0-1KIT	1/4" drive, 50 in. lb. Capacity Joint Rate Simulator / ETT
900-2-01KIT	3/8" drive, 400 in. lb. Capacity Joint Rate Simulator / ETT
900-3-01KIT	3/4" drive, 1000 in. lb. Capacity Joint Rate Simulator / ETT



CALIBRATION EQUIPMENT

Master Transducer Component List

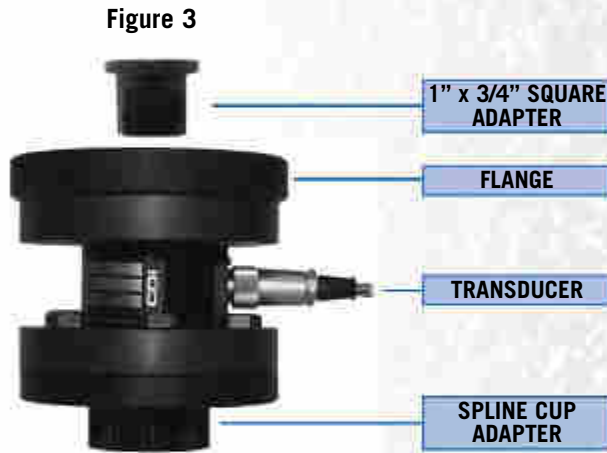
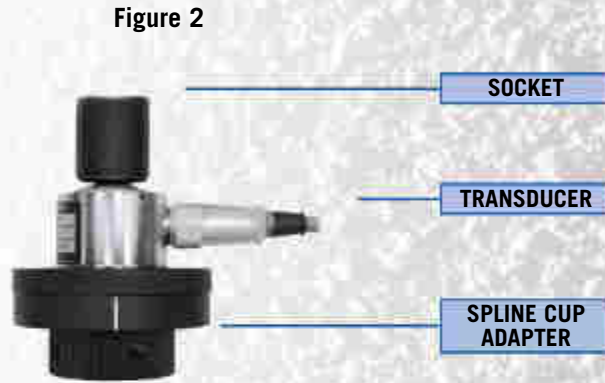
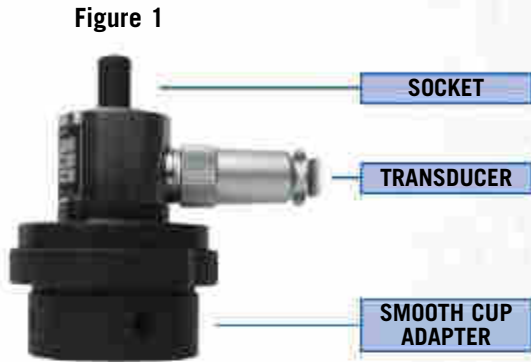

Transducer Kits include all items listed below except brackets. Brackets sold separately.

Transducer Kit Product Code	Range	Drive	Fig. No.	Transducer	Socket	Cup Adapter	Flange	Sq. Drive Adapter	Bracket
2000-4-02	5-50 in. ozs.	1/4"	1	342-17-01	342-40	2000-225-5	none	none	342-35
2000-5-02	15-200 in. ozs.	1/4"	1	342-2-01	342-40	2000-225-5	none	none	342-35
2000-6-02	4-50 in. lbs.	1/4"	1	342-4-01	342-40	2000-225-5	none	none	342-35
2000-65-02	15-150 in. lbs.	1/4"	1	S/342-5-0	342-40	2000-225-5	none	none	342-35
2000-7-02	30-400 in. lbs.	3/8"	1	342-7-0	342-41-2	2000-225-5	none	none	342-35
2000-8-02	80-1000 in. lbs.	3/8"	1	342-9-0	342-41-2	2000-225-5	none	none	342-35
2000-10-02	10-125 ft. lbs.	1/2"	1	342-10-0	65-26-3	2000-225-4	none	none	342-36
2000-11-02	20-250 ft. lbs.	1/2"	1	342-11-0	65-26-3	2000-225-4	none	none	342-36
2000-12-02	60-600 ft. lbs.	3/4"	2	342-12-0	65-78-2	S/2000-225-4	none	none	342-36
2000-13-02	100-1000 ft. lbs.	1"	3	S/2000-13-0	none	S/2000-225-3	S/2000-219-2	2000-226-2	2000-150-03
2000-14-02	200-2000 ft. lbs.	1"	3	S/2000-14-0	none	S/2000-227-2	S/2000-219-2	2000-226-2	2000-150-03

DIGITAL TORQUE TESTER™ (DTT)

TEST THE HEALTH OF YOUR TORQUE WRENCHES - ANYWHERE WITH THE DIGITAL TORQUE TESTER.

Utilizing the testing protocol and standards developed by the American Society of Mechanical Engineers (ASME)

The **Digital Torque Tester™ (DTT)** is designed to be an affordable torque tester that can be mounted on a wall or used in a bench-top vise to allow the operator to conveniently test torque wrenches and torque screwdrivers. It features an easy to use touch pad screen to capture peak torque values during a test in real time, and download stored torque data to a PC. All DTT torque testers are sold in a kit with the complete tester, hard carrying case, a socket driver reducer adapter and AC/DC power supply.



DIGITAL TORQUE TESTER™ (DTT)

Product Code	Female Drive	Range English	Range, Nm	Range, kgcm
1001-O-DTT	1/4"	10 - 100 in.oz.	.07 - .706	.72 - 7.20
501-I-DTT	1/4"	5 - 50 in.lb.	.56 - 5.65	5.76 - 57.60
8001-O-DTT*	1/4"	20 - 800 in.oz.	.001 - .056 cNm	.014 - .56 dNm
2502-I-DTT	3/8"	25 - 250 in.lb.	2.82 - 28.25	23.80 - 288.0
4002-I-DTT	3/8"	40 - 400 in.lb.	4.52 - 45.2	46.08 - 460.8
10002-I-DTT	3/8"	100 - 1000 in.lb.	12 - 112	115 - 1152
2503-F-DTT	1/2"	25 - 250 ft.lb.	33 - 338.96	1.93 - 34.56 kgm
6004-F-DTT	3/4"	60 - 600 ft.lb.	81.35 - 813.5	8.30 - 82.95 kgm

Accuracy: ± 0.50% 10% to 100% CW & CCW of indicated test value @ 25° C (Except 2503-F-DTT)

*Accuracy: ± 1% CW & CCW from 2-1/2% to 100% of full scale. New for Torque Screwdriver.

Units of Measure: Nm, kgcm, ft.lb., in.lb., in.oz., kgm, cNm

Operation Modes: TRACK, PEAK, FIRST PEAK

Operating Temperature: 10 to 32° C (50 to 90° F)

Storage Temperature: -20 to 50° C (-2 to 122° F)

Humidity: 85% Relative Humidity @ 21° C (70° F)

Power Supply: Included 9-volt A/C D/C adapter. 6 AA batteries included.

Data Storage/Recall: Memory Capacity – 500 Records (Complete Check Mode Only.)

Dimensions: W - 10" x H - 16" x D - 2.5"

Weight: (Tester Only) - 10.7 lbs., (with Carrying Case) - 17.4 lbs.



DTT OPTIONAL ACCESSORIES

Product Code	Description
2344-0050-03	Table Mounting Bracket for DTT Series Testers
2344-0051-02	3/8" X 3/8" M X M Sq. Dr. Adaptors
2344-0051-11	1/4" X 1/4" M X M Sq. Dr. Adaptors
2344-0051-16	3/8" X 1/2" M X M Sq. Dr. Adaptors
2344-0051-13	1/2" X 1/2" M X M Sq. Dr. Adaptors
2344-0051-19	3/4" X 1-1/4" M X M Sq. Dr. Adaptors



DIGITAL TORQUE TESTER™ (DTT) QUICK CHECK MODE



Features

- Integral Transducer and sturdy housing allow mounting in virtually any position
- Integral Transducer: Full bridge strain gage, 350 ohm, 1500uE, 3mV/V F.S, 3.75 excitation.
- Units of Torque: Nm, kgcm, ft.lb., in.lb., in-oz.
- Audible (tone) and LED light-bar Present Alerts
- Torque Accuracy: $\pm 0.5\% \pm 1$ count CW and CCW from 10 to 100% of full scale at 25° C
- LCD Touch Screen: 4.7 in. color graphics display
- Screen resolution: 480 X 272 pixels
- Display Accuracy: 4 digits, 9999 cycle counts
- Six "AA" Alkaline cells for battery power included
- Track, Peak and First Peak modes of operation
- Operating Temperature: 40 to 110° F (5 to 42° C)
- Storage Temperature: 0 to 122° F (-20 to 50° C)
- Humidity up to 85% non-condensing
- EU/CE-DE, ES, FR, IT, NL, PT, UK and Japanese language manual
- Certificate of N.I.S.T. traceability from 10% to 100% of full scale
- Includes storage case, AC adapter and USB cable

DIGITAL TORQUE TESTER™ (DTT) AUDIT MODE

The Audit mode is an ASME emulation which tests the wrench at 20%, 60% and 100% of full scale. This provides a complete diagnostic analysis of the wrench. Testing validates the linearity of the wrench.



Select Audit (ASME emulation)



Select Wrench Type



Example shows testing a 250 ft.lb. wrench at 20% of full scale. Yellow indicates low reading.



Example shows testing a 250 ft.lb. wrench at 60% of full scale. Yellow indicates low reading.



Example shows testing a 250 ft.lb. wrench at 100% of full scale. Red indicates high reading.

MULTITORQ TORQUE & DATA COLLECTION SYSTEMS

The **MULTITORQ** portable electronic torque meter displays torque readings from sensors that attach between sockets and driver. MULTITORQ is a highly versatile torque analyzer/data acquisition system that can be used with sockets, extensions, universal joints, ratcheting drivers or any combination of these. Sensors are sold separately, available in 8 ranges from 2-20 in. ozs. to 150-1500 ft. lb. Accuracy $\pm 1\%$ of reading ($\pm 2\%$ reading for 20 in. oz., and 10 in. lb.) 10-100% of sensor range.

The torque analyzer features a wide angle viewing LCD display with selectable readouts; ft. lb., in. lb., in. oz., Nm, dNm, mkg, and cmkg units. Torque target settings are entered via a push button membrane keyboard. High and low torque limits are adjustable to give an audible and visual alarm. The user selects Track mode to display torque values as they are applied, or Peak mode to display the highest torque value applied.

Features

- 4 digit w/ alpha & numerical function flags
- 4 digit, 8000 counts display capacity
- Accuracy: $\pm 1\%$ of indicated value, cw & ccw, from 10% to 100% of full scale, 201-O-MT and 101-I-MT are $\pm 2\%$
- Soft touch keys: hi/lo alarm, zero tare, set-up, units, store/recall/clear, send, statistics, enter
- Units of measurement: ft. lb., in. lb., in. oz., Nm, dNm, mkg and cmkg
- Storage: -20 to 50 degrees C (-2 to 122 degrees F)
- Humidity: up to 90%, non-condensing
- Dimensions: 3" wide, 2.5" high (3" with belt clip), 6" deep
- Weight: 1 pound
- Charge life (full charge to shutoff): 20 hours continuous
- Battery chargers: 120 VAC or 220 VAC (50-60Hz)
- Output: 9VDC, 200mA
- Data storage/recall: 3500 measurements
- Serial output port: RS-232 (true), 300-19.2k baud, and mitutoyo (statistical protocol)
- Rechargeable Ni-Cad batteries
- Reads bi-directionally (cw and ccw)

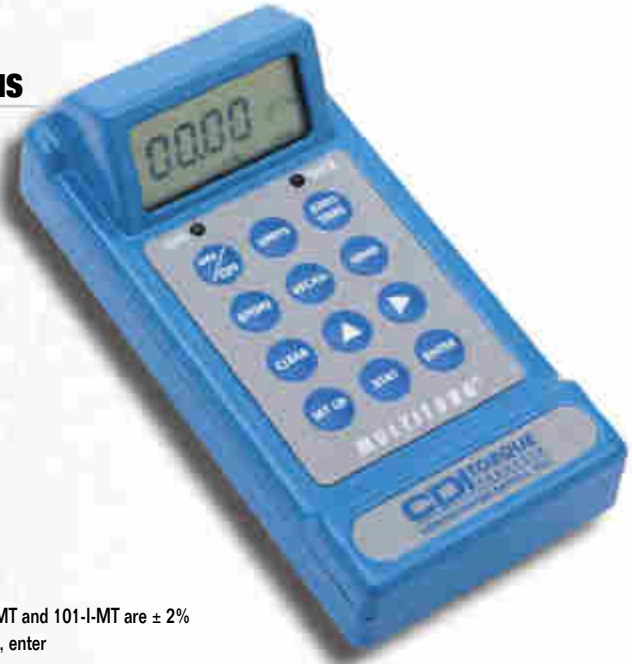

Turns any ordinary ratchet wrench.....



...into a highly accurate digital torque tool.

MULTITORQ TORQUE & DATA COLLECTION SYSTEMS

Standard Set Includes:

Product Code	Description
1600-MT	MULTITORQ Unit includes: power pack/charger (P115-30) and case (1600-50)
1600-MT-220V	Configured as a 220 volt unit

Sensors: (sold separately)

Product Code	Torque Range	Drive
201-O-MT	2 - 20 in. oz.	1/4"
101-I-MT	1 - 10 in. lb.	1/4"
501-I-MT	5 - 50 in. lb.	1/4"
2001-I-MT	20 - 200 in. lb.	1/4"
1002-F-MT	10 - 100 ft. lb.	3/8"
2503-F-MT	25 - 250 ft. lb.	1/2"
6004-F-MT	60 - 600 ft. lb.	3/4"
15005-F-MT	150 - 1500 ft. lb.	1"

Optional Accessories:

Product Code	Description
1600-20	Interface Cable: RS-232 to P.C.
2000-SW	PC Software
82-66	220 Volt Charger

Certificate of accuracy traceable to N.I.S.T. supplied with each transducer.
All components ordered separately.



COMPUTORQ II ELECTRONIC TORQUE WRENCHES

The **COMPUTORQ II** is our state-of-the-art Digital Programmable Torque Wrench. It has many applications, including precision torquing of critical fasteners, tracking applied torque for quality control testing, as well as destructive component testing. The Computorq II is easy to program using the soft touch keypad. Simply program a "target" torque including upper and lower limits, and the wrench will signal with a beep when that torque setting is reached. If the user exceeds the target torque, an alarm tone sounds and the red light flashes. Computorq II is available in six models with ranges from 5 in. lbs. up to 1000 ft. lbs.

Features

- Up to 4000 torque values can be stored in memory
- Downloading capability to a printer/computer datalogger via RS232
- Selectable modes of operation are "peak hold" and "track"
- Target torque values are easily programmed and viewed through the keypad
- Available torque ranges from 5 in. lb. to 1000 ft. lb.
- A 9v alkaline battery is standard for 60 hours of operation
- Accuracy: $\pm 1\%$ of indicated value, CW & CCW, from 20% to 100% of full scale;
 $\pm 1\%$, plus 5 increments from 10% to 20% of full scale
- All calibration data is stored in the microprocessor
- Selectable baud rate for downloading to a printer/computer/datalogger.
Options are 300, 600, 1200, 2400, 4800, 9600, or 19200
- Meets or exceeds ASME B107.28 - 2005

COMPUTORQ II ELECTRONIC TORQUE WRENCHES

Product Code	Drive	Torque Range	Incr.	Length In.	Wt. Lbs.	Product Code	Drive	Torque Range	Incr.	Length In.	Wt. Lbs.
501CI-II	¼"	5 - 50 in. lb.	.01 in. lb.	13.5	1.5	2503CF-II	½"	300 - 3000 in. lb.	1 in. lb.	21.5	3.2
		.4 - 4.2 ft. lb.	.001 ft. lb.					25 - 250 ft. lb.	.1 ft. lb.		
		5.6 - 56 dNm	.01 dNm					340 - 3380 dNm	2 dNm		
		.56 - 5.6 Nm	.01 Nm					34 - 338 Nm	.1 Nm		
		5.7 - 57 cmkg	.01 cmkg					340 - 3400 cmkg	2 cmkg		
		.057 - .57 mkg	.001 mkg					3.4 - 34 mkg	.01 mkg		
2502CI-II	⅜"	25 - 250 in. lb.	.1 in. lb.	14.9	2.0	6004CF-II	¾"	720 - 7200 in. lb.	3 in. lb.	46.5	9.5
		2 - 20 ft. lb.	.01 ft. lb.					60 - 600 ft. lb.	.2 ft. lb.		
		28 - 282 dNm	.1 dNm					810 - 8130 dNm	.1 ft. lb.		
		2.8 - 28 Nm	.01 Nm					81 - 813 Nm	.1 Nm		
		29 - 288 cmkg	.1 cmkg					830 - 8300 cmkg	4 cmkg		
		.29 - 2.88 mkg	.001 mkg					8.3 - 83 mkg	.01 mkg		
502CF-II	⅝"	60 - 600 in. lb.	.1 in. lb.	14.9	2.0	10005CF-II	1"	100 - 1000 ft. lb.	.1 ft. lb.	74.0	19.0
		5 - 50 ft. lb.	.01 ft. lb.					135 - 1355 Nm	.1 Nm		
		68 - 677 dNm	.1 dNm					14 - 138 mkg	1 mkg		
		6.8 - 67.7 Nm	.01 Nm								
		69.1 - 691 cmkg	.1 cmkg								
		.7 - 6.9 mkg	.001 mkg								

Optional Cables: Product Code P113-50 Computorq to 9 Pin P.C.

Optional Cables: Product Code P113-60 Computorq to 25 Pin Printer

N.I.S.T. traceable calibration certificate included.



COMPUTORQ 3 ELECTRONIC TORQUE WRENCHES

The **COMPUTORQ 3** Electronic Torque Wrench is a simple to use digital readout wrench that displays real time torque values in any of four torque units, ft.lbs., in.lbs., Nm, kg.cm. Simply set the desired torque value and apply force until the green LED illuminates. Great for light industrial, automotive, motorcycle, watercraft and aircraft applications.

Features

- Sleek new design
- 15-degree flex ratcheting head
- Push button socket release head
- Large, easy to read digital display
- Long battery life, uses 2 each CR123 lithium batteries
- Ergonomically designed molded non-slip rubber grip
- Torques in both clockwise and counterclockwise directions
- Battery saving auto-shutoff after two minutes
- COMPUTORQ 3 remembers last unit and torque setting selected
- Audible tone sounds when set torque value is reached, if the set torque value is exceeded, an alarm tone will sound.
- 3 color LED light bar
 - YELLOW LED indicates approaching desired torque setting
 - GREEN LED indicates desired torque value is reached
 - RED LED indicates fastener was overtorqued, loosen and retighten.
- When desired torque value is reached, display will hold value and flash for ten seconds.
- COMPUTORQ 3 will operate in any of four torque units, foot pounds (ft. lbs.), inch pounds (in. lbs.), newton meter (Nm) or kilogram centimeter (kg. cm.).
- **ACCURACY:**
 - ±2% CW of readings from 20% to 100% of full scale
 - ±3% CCW of readings from 20% to 100% of full scale
- N.I.S.T. traceable certificate of calibration included



STANDARD MODELS

Product Code	Drive	Ft. Lb.	In. Lb.	Nm	Kg. Cm.	Length In. (mm)	Wt. Lbs. (kgs)
2401CI3	¼"	2.0 - 20.0	24 - 240	2.71 - 27.10	27.6 - 276	15 (381)	2.0 (.91)
1002CF3	⅜"	10.0 - 100.0	120 - 1200	13.6 - 135.6	138 - 1382	17 (432)	2.2 (1.0)
2503CF3	½"	25 - 250	300 - 3000	33.8 - 338	345 - 3456	27 (686)	3.5 (1.59)



HIGH ACCURACY MODELS

Product Code	Drive	Ft. Lb.	In. Lb.	Nm	Kg. Cm.	Length In. (mm)	Wt. Lbs. (kgs)
2401CI3HA*	¼"	2.0 - 20.0	24 - 240	2.71 - 27.10	27.6 - 276	15 (381)	2.0 (.91)
1002CF3HA*	⅜"	10.0 - 100.0	120 - 1200	13.6 - 135.6	138 - 1382	17 (432)	2.2 (1.0)
2503CF3HA*	½"	25 - 250	300 - 3000	33.8 - 338	345 - 3456	27 (686)	3.5 (1.59)

The certification of accuracy provided per ASME and ISO Standards is 20% to 100% of full scale.

***HIGH ACCURACY 1% Clockwise direction only.** **It couldn't be easier to use!**



COMPUTORQ 3 Display and 3 Color LED Light Bar





TORQUE & ANGLE™ ELECTRONIC TORQUE WRENCHES

The CDI **Torque and Angle Electronic Wrench** incorporates 21st Century Technology in a simple to use digital wrench. Specifically designed to meet the needs of the torque professional where torque plus angle is required. It features three units of torque, ft.lbs. In.lbs. and Nm as well as the angle mode.

The Torque and Angle wrench allows the technician to apply a specific torque load, followed by the angle specification, all in one convenient wrench. It features a three LED light bar and audible buzzer. As the angle mode is a separate function, the wrench can also be used as a stand alone digital torque wrench.

Features

- Accuracy is +/- 2% CW, +/- 3% CCW of indicated value
- Gyro chip senses 360° of movement, and is accurate to within +/- 3.8°
- No maintenance, just change batteries at 80 hours
- VERY easy to set up and use quickly
- Almost impossible to over torque
- Digital torque measurement and digital angle measurement in one convenient package
- Ergonomic non-slip cushion grip
- 15% Flex Ratchet head
- Long battery life, uses two CR123 lithium batteries
- Convenient, push button socket release ratchet head
- 3 step LED visual signal system:
 - Yellow Light = approaching target torque
 - Green Light = target torque reached
 - Red Light = over torque indicator
- N.I.S.T. traceable certificate of calibration included

TORQUE & ANGLE™ ELECTRONIC TORQUE WRENCHES

Product Code	Drive	Ft. Lb.	In. Lb.	Nm	Angle	Length In. (mm)	Wt. Lbs. (kgs)
1002TAA-CDI	3/8"	10 - 100	120 - 1200	12.6 - 135.6	0-360°	17 (432)	2.2 (1.0)
2503TAA-CDI	1/2"	25 - 250	300 - 3000	33.8 - 338	0-360°	27 (686)	3.5 (1.59)

The certification of accuracy provided per ASME and ISO Standards is 20% to 100% of full scale.



The yellow LED illuminates within 10% of target torque.

The green LED illuminates within 4% of target torque. Continuous buzzer sounds when target is reached.

The red LED illuminates 4% beyond target torque, indicating fastener was overtorqued. Rapid "alarm" buzzer sounds.

HEAVY-DUTY TORQUE & ANGLE™ TORQUE WRENCH

LEADING THE WAY IN HEAVY-DUTY TORQUE AND ANGLE APPLICATIONS WITH INNOVATIVE SOLUTIONS THAT MAKE A DIFFERENCE IN DOING THE JOB RIGHT.

The CDI **600 ft.lb. Heavy-Duty Torque & Angle™ Torque Wrench** eliminates the need for angle gauges and protractors, providing the most accurate and efficient way to achieve torque plus angle tightening sequences now specified by many manufacturers. The digital readout displays a torque setting then with a push of a button, switches to the angle mode. Angle readout not affected by ratcheting. Angle calculation based on the same gyroscopic technology that maintains helicopters at level flight.

- Torque Accuracy: (2% CW & 3% CCW FROM 20 – 100% F.S.)
(4% CW & 6% CCW FROM 10 – 19% F.S.)
- Angle Accuracy: ± 3.8% of indicated value
- Angular Display Resolution: 1°

Features

- Torque Units: ft.lb., in.lbs., Nm
- Audible (tone) Preset Alerts
- Display Resolution: 0.1 ft.lb., 0.1 Nm, 1 in.lb.
- Comfortable non-slip grip handle
- Sealed Ratchet Head
- 4 "AA" Alkaline Batteries Included
- Low Battery Indicator and Auto Shutoff after two minutes idle
- Operating Temperature: 40 - 110° F. (5 - 42° C)
- Storage Temperature: 0 - 122° F (-20 - 50° C)
- Humidity up to 90% non-condensing
- EU/CE-DE, ES, FR, IT, NL, PT, UK and Japanese language manual
- Certificate of N.I.S.T. traceability for 20% to 100% of full scale
- Includes storage case

HEAVY-DUTY TORQUE & ANGLE™ TORQUE WRENCH

Product Code	Drive	Ft. Lb.	In. Lb.	Nm	Angle	Length	Wt.
						In. (mm)	Lbs. (kgs)
6004TAA	3/4"	120 - 600	1440 - 7200	156 - 780	0-360°	49 (1244.6)	14 (6.35)





ELECTRONIC DIAL TORQUE WRENCH

The new **Electronic Dial (ED)** torque wrench features solid-state electronics for accurate torque application and measurement. ED's design provides easy set-up and usage. There is no need to look directly at the digital readout as the wrench features 3 indicating lights and an audible buzzer.

The ED wrench has unsurpassed reliability and durability -- 21st century technology in a simple, easy to read digital torque wrench.

Features

- 4 units of measure...ft lb, in lb, Nm, kg.cm.
- Accuracy: ± 1% of indicated value CW & CCW, from 20% to 100% of full scale
- 3 step LED visual signal system
 YELLOW LIGHT = approaching target torque
 GREEN LIGHT = target torque reached
 RED LIGHT = over torque indicator
- Audible tone when desired torque is reached
- Alarm tone sounds if wrench is overtorqued
- Ergonomically designed wrench body
- Display can be turned 180 degrees to allow left hand usage
- Battery cover designed to be aviation FOD proof
- Holds "peak" torque reading for 10 seconds
- Constructed of special Capron® material for long life and durability
- Resistant to the majority of chemicals used in industrial environments
- Wrench can be hung on tool board
- Bar graph displays orientation of torque application (left or right hand)
- Uses standard 9 volt alkaline battery
- N.I.S.T. traceable certificate of calibration included
- Meets or exceeds ASME B107.28 – 2005

ELECTRONIC DIAL TORQUE WRENCH

Product Code	Drive	In. Lb.	Ft. Lb.	Nm	Kg. Cm.	Length In. (mm)	Wt. Lbs. (kgs)
501ED-CDI	¼"	5 - 50	.42 - 4.17	.56 - 5.65	57 - 57.61	11.5 (292)	1.25 (.57)
2502ED-CDI	⅜"	25 - 250	2.08 - 20.83	2.82 - 28.25	28 - 280.03	14.5 (368)	1.51 (.68)
6002ED-CDI	½"	60 - 600	5 - 50	6.79 - 67.79	69 - 691.27	14.5 (368)	1.51 (.68)



CDI "ED": Easy to change dial orientation.



The yellow LED illuminates within 10% of target torque.



The green LED illuminates within 4% of target torque. Continuous buzzer sounds when target is reached.



The red LED illuminates 4% beyond target torque, indicating fastener was overtorqued. Rapid "alarm" buzzer sounds.

TORQUE SCREWDRIVERS - MICRO-ADJUSTABLE

Adjustable models offer versatility for applications that require more than one torque value. These torque screwdrivers are particularly suited for the electronics industry and for instrument assembly work. A simple, cam-over design prevents over-tightening and possible damage to components.

Torque settings are easily and accurately changed with a unique adjusting knob and easy-to-read window scale. Adjusting the screwdriver is simple. Just pull out the adjusting knob to unlock, turn to the desired setting, then push the knob in until it clicks!

Positive locking knob makes accidental setting changes impossible. Automatic lock in counterclockwise direction makes fastener removal a snap. The Micro-Adjustable series includes six models with torque settings ranging from 20 in. ozs. to 40 in. lbs.

Features

- 6 models available
- Positive locking pull down adjustment knob
- Trilobular comfort grip
- Universal 1/4" hex bit holder with strong rare earth magnet
- Cam-over torque limiting clutch
- Slip resistant finish
- Easy-to-read window scale
- Light weight
- Automatic lock in CCW direction for disassembly
- Accuracy: $\pm 6\%$ of indicated value, CW, from 20% to 100% of full scale
- Individually serialized with matching certificate of calibration traceable to N.I.S.T.
- Meets or exceeds ASME B107.14 - 2004



TORQUE SCREWDRIVERS - MICRO-ADJUSTABLE

Product Code	Torque Range	Increments	W x L	
			Inches	Wt. Oz.
61SM	20 - 100 in. ozs.	1 in. oz.	1.1 x 5.5	6.8
151SM	3 - 15 in. lbs.	.2 in. lbs.	1.1 x 6.25	8.0
401SM	5 - 40 in. lbs.	.5 in. lbs.	1.2 x 6.75	10.8
61NSM	10 - 80 cNm	1 cNm	1.1 x 5.5	6.8
151NSM	40 - 200 cNm	2 cNm	1.1 x 6.25	8.0
401NSM	50 - 450 cNm	5 cNm	1.2 x 6.75	10.8





TORQUE SCREWDRIVERS - SINGLE SETTING

The tamper resistant design of the **Single Setting** series is particularly suited for high-volume use in assembly operations. A simple, cam-over design prevents over-tightening and possible damage to components.

Torque screwdrivers may be ordered factory pre-set at an additional charge or they may be easily set by the operator with any quality torque calibration system. The end cap removes for easy access to the 1/8" hex adjustment screw. A hex adjustment key is included with each driver.

The Single Setting series includes four models with available torque settings from 6 in. ozs. up to 40 in.lbs. When precision and repeatability are a must, the choice is simple - CDI Torque Screwdrivers.

Features

- Factory Pre-Set models are set at the factory to the customer's specified torque setting and are furnished with a Certificate of Calibration
- Please specify desired torque setting when order is placed
- 4 models available
- Trilobular comfort grip
- Universal 1/4" hex bit holder with strong rare earth magnet
- Cam-over torque limiting clutch
- Rugged, light weight aluminum body
- Automatic lock in CCW direction
- Accuracy: ± 6% of indicated value, CW, from 20% to 100% of full scale
- Meets or exceeds ASME B107.14 - 2004

TORQUE SCREWDRIVERS - SINGLE SETTING

Product Code Un-Set	Product Code Factory Pre-Set	Torque Range	W X L Length	Wt. Oz.
21SP	21SP-SET	6-32 in.ozs	1.1 x 4.5	5.3
61SP	61SP-SET	10 - 100 in.ozs.	1.1 x 5.6	7.0
151SP	151SP-SET	1.5 - 15 in. lbs	1.1 x 5.6	7.0
401SP	401SP-SET	4 - 40 in. lbs.	1.2 x 6.3	9.6



TORKY - SINGLE SETTING WRENCHES

CDI's **TORKY** is a right angle pre-set torque wrench. Torky is designed for production torque applications that require higher values than a torque screwdriver can deliver. The comfortable design eases the strain of repeated uses. Torque value may be ordered factory pre-set at an additional charge or it may be easily set by the operator with any quality torque calibration system. When the proper torque value is reached, a momentary release or "break" can be felt. Available in three drive styles to fit most needs.

Features

- Factory Pre-Set models are set at the factory to the customer's specified torque setting and are furnished with a Certificate of Calibration
- Please specify desired torque setting when order is placed
- Three models available
- Simple, easy to use design
- Ruggedly built for years of reliable service
- Operates bi-directionally
- Accuracy: ± 6% of indicated value, CW, from 20% to 100% of full scale



Prevents premature wear of carbide inserts and damage to cutter head due to improper clamp load.

TORKY - SINGLE SETTING WRENCHES

Product Code Un-Set	Product Code Factory Pre-Set	Drive	Torque Range	W X L Length	Wt. Oz.
1501TPA-1	1501TPA-1-SET	1/4" Female Hex	20-170 in.lbs.	1 x 5.25	8.3
1501TP-1	1501TP-1-SET	1/4" Male Square	20-170 in.lbs.	1 x 5.25	8.3
1502TP-1	1502TP-1-SET	3/8" Male Square	20-170 in.lbs.	1 x 5.25	8.3



DIAL TORQUE WRENCHES - SINGLE SCALE

Dial Torque Wrenches are designed for the automotive, nuclear and industrial markets in addition to military installations throughout the world. This series features sturdy torsion beam design for dependable long life and accuracy. The small frame model offers working ranges from 3 in. lbs. to 50 ft. lbs. in 1/4" and 3/8" drives. The large frame model continues from 100 ft. lbs. through 2,000 ft. lbs. with 1/2", 3/4" and 1" drives. Accuracy of both series of $\pm 3\%$ meets or exceeds B107.14 - 2004, ISO 6789 bi-directionally from 20% to 100% of scale. All wrenches supplied with a N.I.S.T. traceable certificate of calibration.

Features

- Sturdy body construction insures maximum durability
- Easy to read laser marked single scale
- Large easy to read dial is shock resistant and protected by a tough metal guard
- Memory needle retains highest torque reading applied
- Calibrated in both CW and CCW direction
- Accuracy: $\pm 3\%$ of indicated value, CW & CCW, from 20% to 100% of full scale
- Individually serialized with matching certificate of calibration traceable to N.I.S.T.



DIAL TORQUE WRENCHES - SINGLE SCALE

Product Code	Drive Size (In.)	English Range	Incr.	A In.	B In.	C In.	D In.	WT. Lbs.
Memory Needle Models								
301LDINSS	1/4"	0-30 in.lb.	.5 in.lb.	11.5	1.1	1.2	2.75	1.1
751LDINSS	1/4"	0-75 in.lb.	1 in.lb.	11.5	1.1	1.2	2.75	1.1
752LDINSS	3/8"	0-75 in.lb.	1 in.lb.	11.5	1.1	1.2	2.75	1.1
3002LDINSS	3/8"	0-300 in.lb.	5 in.lb.	11.5	1.1	1.2	2.75	1.1
6002LDINSS	3/8"	0-600 in.lb.	10 in.lb.	15	1.5	1.2	2.75	1.6
502LDFNSS	3/8"	0-50 ft.lbs.	1 ft.lb.	15	1.5	1.2	2.75	1.6
1003LDFNSS	1/2"	0-100 ft. lb.	2 ft. lb.	21.75	2.25	1.50	2.75	3.70
1753LDFNSS	1/2"	0-175 ft. lb.	5 ft. lb.	21.75	2.25	1.50	2.75	3.70
2503LDFNSS	1/2"	0-250 ft. lb.	5 ft. lb.	21.75	2.25	1.50	2.75	3.70
3504LDFNSS	3/4"	0-350 ft. lb.	10 ft. lb.	28.00	2.25	1.50	2.75	5.75
6004LDFNSS*	3/4"	0-600 ft. lb.	10 ft. lb.	47.00	2.50	1.50	2.75	10.10
10005LDFNSS*	1"	0-1000 ft. lb.	20 ft. lb.	74.00	2.50	3.50	3.00	30.00
Electric Signaling Models								
6004LDFESS**	3/4"	0-600 ft. lb.	10 ft. lb.	47.00	2.50	1.50	2.75	10.10
10005LDFESS**	1"	0-1000 ft. lb.	20 ft. lb.	74.00	2.50	3.50	3.00	30.00
20005LDFESS***	1"	0-2000 ft. lb.	40 ft. lb.	122.00	3.50	6.50	3.50	47.00

**NOTE: 6004LDFNSS and 10005LDFNSS include 1 extension handle.

**NOTE: 6004LDFESS and 10005LDFESS include 1 extension handle, indicating light and buzzer.

***NOTE: 20005LDFESS is a "T" style wrench with 1" drive female head that can be used with a torque multiplier. Includes 5 piece handle assembly, indicating light and buzzer.



T-TYPE DIAL WRENCHES must be operated by two persons or a torque multiplier. The handle is over 10 ft. long.

DIAL TORQUE WRENCHES NEWTON METER - SINGLE SCALE

DIAL TORQUE WRENCHES NEWTON METER - SINGLE SCALE

Product Code	Drive Size (In.)	Nm Range	Incr.	A In.	B In.	C In.	D In.	Wt. Lbs.
Memory Needle Models								
1.81NLDNSS	¼"	0-1.8 Nm	.05 Nm	11.5	1.1	1.2	2.75	1.1
3.51NLDNSS	¼"	0-3.5 Nm	.1 Nm	11.5	1.1	1.2	2.75	1.1
91NLDNSS	¼"	0-9 Nm	.2 Nm	11.5	1.1	1.2	2.75	1.1
92NLDNSS	⅜"	0-9 Nm	.2 Nm	11.5	1.1	1.2	2.75	1.1
182NLDNSS	⅜"	0-18 Nm	.5 Nm	11.5	1.1	1.2	2.75	1.1
302NLDNSS	⅜"	0-30 Nm	.5 Nm	11.5	1.1	1.2	2.75	1.1
352NLDNSS	⅜"	0-35 Nm	1 Nm	11.5	1.1	1.2	2.75	1.1
702NLDNSS	⅜"	0-70 Nm	2 Nm	15	1.5	1.2	2.75	1.6
1403NLDNSS	½"	0-140 Nm	2.5 Nm	21.75	2.25	1.50	2.75	3.70
2403NLDNSS	½"	0-240 Nm	5 Nm	21.75	2.25	1.50	2.75	3.70
3503NLDNSS	½"	0-350 Nm	10 Nm	21.75	2.25	1.50	2.75	3.70
4804NLDNSS	¾"	0-480 Nm	10 Nm	28.00	2.25	1.50	2.75	5.75
8004NLDNSS*	¾"	0-800 Nm	20 Nm	47.00	2.50	1.50	2.75	10.10
14005NLDNSS*	1"	0-1400 Nm	25 Nm	74.00	2.50	3.50	3.00	30.00

*NOTE: 8004NLDNSS and 14005NLDNSS include 1 Extension handle.



DIAL TORQUE WRENCHES - DUAL SCALE

Dial Torque Wrenches are designed for the automotive, nuclear and industrial markets in addition to military installations throughout the world. This series features sturdy torsion beam design for dependable long life and accuracy. The small frame model offers working ranges from 3 in. lbs. to 50 ft. lbs. in 1/4" and 3/8" drives. The large frame model continues from 100 ft. lbs. through 2,000 ft. lbs. with 1/2", 3/4" and 1" drives. Accuracy of both series of $\pm 3\%$ meets or exceeds B107.14 - 2004, ISO 6789 bi-directionally from 20% to 100% of scale. All wrenches supplied with a N.I.S.T. traceable certificate of calibration.

Features

- Sturdy body construction insures durability
- Easy to read laser marked dual scale
- Large easy to read dial is shock resistant and protected by a tough metal guard
- Memory needle retains highest torque reading applied
- Calibrated in both CW and CCW direction
- Accuracy: $\pm 3\%$ of indicated value, CW & CCW, from 20% to 100% of full scale
- Individually serialized with matching certificate of calibration traceable to N.I.S.T.



DIAL TORQUE WRENCHES - DUAL SCALE

Product Code	Drive Size	English Range	Incr.	Nm Range	Incr.	A In.	B In.	C In.	D In.	Wt. Lbs.
Memory Needle Models										
301LDIN	1/4"	0-30 in. lb.	.5 in. lb.	0-3.5 Nm	.1 Nm	11.5	1.1	1.2	2.75	1.1
751LDIN	1/4"	0-75 in. lb.	1 in. lb.	0-9 Nm	.2 Nm	11.5	1.1	1.2	2.75	1.1
1502LDIN	3/8"	0-150 in. lb.	2 in. lb.	0-18 Nm	.5 Nm	11.5	1.1	1.2	2.75	1.1
2502LDIN	3/8"	0-250 in. lb.	5 in. lb.	0-30 Nm	.5 Nm	11.5	1.1	1.2	2.75	1.1
3002LDIN	3/8"	0-300 in. lb.	5 in. lb.	0-35 Nm	1 Nm	11.5	1.1	1.2	2.75	1.1
6002LDIN	3/8"	0-600 in. lb.	10 in. lb.	0-70 Nm	2 Nm	15	1.5	1.2	2.75	1.6
502LDFN	3/8"	0-50 ft. lb.	1 ft. lb.	0-70 Nm	2 Nm	15	1.5	1.2	2.75	1.6
1003LDFN	1/2"	0-100 ft. lb.	2 ft. lb.	0-140 Nm	2.5 Nm	21.75	2.25	1.50	2.75	3.70
1753LDFN	1/2"	0-175 ft. lb.	5 ft. lb.	0-240 Nm	5 Nm	21.75	2.25	1.50	2.75	3.70
2503LDFN	1/2"	0-250 ft. lb.	5 ft. lb.	0-350 Nm	10 Nm	21.75	2.25	1.50	2.75	3.70
3504LDFN	3/4"	0-350 ft. lb.	10 ft. lb.	0-480 Nm	10 Nm	28.00	2.25	1.50	2.75	5.75
6004LDFN*	3/4"	0-600 ft. lb.	10 ft. lb.	0-800 Nm	20 Nm	47.00	2.50	1.50	2.75	10.10
10005LDFN*	1"	0-1000 ft. lb.	20 ft. lb.	0-1400 Nm	25 Nm	74.00	2.50	3.50	3.00	30.00
Electric Signaling Models										
6004LDFE**	3/4"	0-600 ft. lb.	10 ft. lb.	0-800 Nm	20 Nm	47.00	2.50	1.50	2.75	10.10
10005LDFE**	1"	0-1000 ft. lb.	20 ft. lb.	0-1400 Nm	25 Nm	74.00	2.50	3.50	3.00	30.00
20005LDFE***	1"	0-2000 ft. lb.	40 ft. lb.	0-2800 Nm	50 Nm	122.00	3.50	6.50	3.50	47.00

*NOTE: 6004LDFN and 10005LDFN include 1 Extension handle.

**NOTE: 6004LDFE and 10005LDFE include 1 Extension handle, indicating light and buzzer.

***NOTE: 20005LDFE is a "T" style wrench with 1" drive female head that can be use with a torque multiplier. Includes 5 piece handle assembly, indicating light and buzzer.



20005LDFE "T" type Dial Wrench must be operated by two persons or a torque multiplier. The handle is over 10 ft. long.



COMFORT GRIP MICROMETER ADJUSTABLE TORQUE WRENCHES - DUAL SCALE

Comfort-Grip Handle Dual Scale

Features

- Dual scale, calibrated dual direction
- Positive lock with spring loaded pull down lock ring
- Fast, accurate and easy to set
- Easy-to-read laser marked scale
- Most feature quick release buttons which provide good socket retention as well as easy socket removal
- Ergonomic comfort-grip
- Accuracy: $\pm 3\%$ CW $\pm 5\%$ CCW of indicated value, CW, from 20% to 100% of full scale
- Meets or exceeds ASME B107.14-2004, ISO 6789 standards
- Individually serialized with matching certificate of calibration traceable to N.I.S.T.



COMFORT GRIP MICROMETER ADJUSTABLE TORQUE WRENCHES - DUAL SCALE

Product Code	Drive Size	English Range	Incr.	Nm Range	Incr.	A In.	B In.	C In.	D In.
1501MRPH	1/4"	20-150 in. lb.	1	2.8 - 15.3 Nm	.12	10.00	1.06	.93	1.06
2502MRPH	3/8"	30-250 in. lb.	1	4.0 - 27.7 Nm	.12	11.25	1.06	1.06	1.06
10002MRPH	3/8"	150-1000 in. lb.	5	19.8 - 110.2 Nm	.6	16.00	1.43	1.20	1.40
1002MFRPH	3/8"	10-100 ft. lb.	1	16.9 - 132.2 Nm	.7	16.00	1.43	1.20	1.40
1503MFRPH	1/2"	20-150 ft. lb.	1	34 - 197 Nm	1.4	19.00	1.70	1.40	1.40
2503MFRPH	1/2"	30-250 ft. lb.	1	47 - 332 Nm	1.4	24.40	1.70	1.40	1.40
6004MFRPH	3/4"	100-600 ft. lb.	5	169 - 779 Nm	6.8	42.00	2.50	2.10	1.40

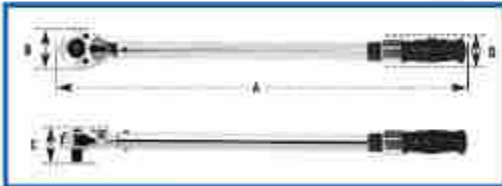

METAL HANDLE CLICK TYPE TORQUE WRENCHES - DUAL SCALE

Metal Handle Dual Scale. The metal handle series offers the user a rugged, industrial strength torque wrench able to withstand the rigors of professional use. Handles are lightly knurled for a tough, non-slip grip. There are 21 models of metal handle micrometer adjustable torque wrenches available.

Features

- Dual scale, calibrated dual direction
- Positive lock with spring loaded pull down lock ring
- Fast, accurate and easy to set
- Easy-to-read laser marked scales
- Most feature quick release buttons which provide good socket retention as well as easy socket removal
- Accuracy: $\pm 3\%$ CW $\pm 4\%$ CCW of indicated value, CW, from 20% to 100% of full scale
- Individually serialized with matching certificate of calibration traceable to N.I.S.T.



METAL HANDLE CLICK TYPE TORQUE WRENCHES - DUAL SCALE

Product Code	Drive Size	English Range	Incr.	Nm Range	Incr.	A In.	B In.	C In.	D In.	Wt. Lbs.
501MRMH	1/4"	10-50 in. lb.	0.5	1.4 - 5.4 Nm	0.5	10.15	1.06	0.93	1.06	0.85
1501MRMH	1/4"	20-150 in. lb.	05	2.8-15.3 Nm	0.12	10.15	1.06	0.93	1.06	0.90
1502MRMH	3/8"	20-150 in. lb.	1	2.8 - 15.3 Nm	.12	10.15	1.06	0.93	1.06	0.90
2002MRMH	3/8"	30-200 in. lb.	1	4.0 - 22.0 Nm	.12	10.15	1.06	0.93	1.06	0.85
2502MRMH	3/8"	30-250 in. lb.	1	4.0 - 27.7 Nm	.12	11.25	1.06	0.93	1.06	0.95
7502MRMH	3/8"	100-750 in. lb.	5	14.1 - 81.9 Nm	.6	16.00	1.43	1.20	1.40	2.50
10002MRMH	3/8"	150-1000 in. lb.	5	19.8 - 110.2 Nm	.6	16.00	1.43	1.20	1.40	2.50
25003MRMH	1/2"	300-2500 in. lb.	10	39.6 - 276.9 Nm	1.2	18.00	1.70	1.40	1.40	3.20
752MFRMH	3/8"	5-75 ft. lb.	0.5	10.2 - 98.3 Nm	.7	16.00	1.43	1.20	1.40	2.50
1002MFRMH	3/8"	10-100 ft. lb.	0.5	16.9 - 132.2 Nm	.7	16.00	1.43	1.20	1.40	2.55
1503MFRMH	1/2"	20-150 ft. lb.	1	34 - 197 Nm	1.4	19.00	1.70	1.40	1.40	3.15
2503MFRMH	1/2"	30-250 ft. lb.	1	47 - 332 Nm	1.4	24.40	1.70	1.40	1.40	3.15
4004MFRMH	3/4"	80-400 ft. lb.	5	85 - 491 Nm	3.4	34.25	2.50	2.10	1.40	10.30
4504MFRMH	3/4"	75-450 ft. lb.	5	119 - 593 Nm	3.40	34.25	2.50	2.10	1.40	10.30
6004MFRMH	3/4"	100-600 ft. lb.	5	169 - 779 Nm	6.8	42.00	2.50	2.00	1.15	11.85
10005MFRMH*	1"	200-1000 ft. lb.	5	305 - 1322 Nm	6.8	70.00	3.00	3.00	1.50	25.10
20005MFMHSS**	1"	300-2000 ft. lb.	10	N/A	N/A	108.50	3.15	4.25	1.65	48.75

*NOTE: 10005MFRMH supplied with one extension handle and is packed in a metal box.

**NOTE: 20005MFMHSS (English scale only) supplied with two extension handles, fixed/non-ratcheting head and is packed in a sturdy cardboard box.



MICROMETER ADJUSTABLE NEWTON METER TORQUE WRENCHES - SINGLE SCALE

Single Scale



MICROMETER ADJUSTABLE NEWTON METER TORQUE WRENCHES - SINGLE SCALE

Product Code	Nm Range	Sq. Drive	Incr.	A In.	B In.	C In.	D In.	Wt. Lbs.
602NMRMHSS	10-60 Nm	3/8"	0.5	16.00	1.43	1.20	1.40	2.50
1002NMRMHSS	20-100 Nm	3/8"	0.5	16.00	1.43	1.20	1.40	2.50
2003NMRMHSS	40-200 Nm	1/2"	2	19.00	1.70	1.40	1.40	3.25
3403NMRMHSS	60-340 Nm	1/2"	2	24.40	1.70	1.40	1.40	3.40
8004NMRMHSS	150-800 Nm	3/4"	5	42.00	2.50	2.10	1.40	11.85
15005NMRMHSS*	300-1500 Nm	1"	10	70.00	3.00	3.00	1.50	25.10

*NOTE: 15005NMRMHSS supplied with one extension handle and is packed in a metal box.

NOTE: All single scale Newton Meter only.



QUICK SET SPLIT BEAM TORQUE WRENCHES

This unique "split beam" measuring element provides consistently accurate readings and rugged, trouble-free performance. Fast setting of desired torque is easily accomplished by rotating adjustment knob until required torque value is displayed in the torque window. 3/4" drive model features three-piece construction for easy disassembly and storage.

Features

- CDI Sealed Ratchet Head - is virtually maintenance free; more time working with the tool, less time on tool maintenance
- Thumb Screw Type Adjustment - is faster than cycling through a micrometer style torque wrench. Guard prevents setting from being changed accidentally. Setting is displayed in window. Conversion table to Nm displayed on handle
- Sealed Neck - keeps dust and grit away from the torque mechanism for longer tool life
- "Split Beam" Measuring Element - provides accurate, reliable readings and eliminates the heavy coil spring used in conventional click type wrenches. This yields fewer moving parts, reducing friction and wear
- Cushion Grip Handle - provides comfort plus control and resists most automotive fluids
- Designed for measuring torque in a clockwise direction only. Wrench is not reversible
- Guaranteed Accuracy: Accurate within $\pm 4\%$ of any clockwise setting from 20% of full scale to full scale.



QUICK SET SPLIT BEAM TORQUE WRENCHES

Product Code	Drive Size	Range	Increments	Length (in.)	Ratchet
WSC-50A	3/8"	120-600 in. lbs.	10.0 in. lbs.	17 1/8	Flex-Head
WSC-100CA	3/8"	20-100 ft. lbs.	2.0 ft. lbs.	17 1/8	Flex-Head
WSC-250CA	1/2"	40-250 ft. lbs.	5.0 ft. lbs.	21 7/16	Flex-Head
WSC-400CA	3/4"	80-400 ft. lbs.	10.0 ft. lbs.	38 1/8	Fixed-Head
WSC-600CA	3/4"	200-600 ft. lbs.	10.0 ft. lbs.	48 1/2	Fixed-Head



FLEX-HEAD MICROMETER ADJUSTABLE TORQUE WRENCH

Flex-Head English Single Scale

Features

- Single scale, dual direction
- Positive lock with spring loaded pull down lock ring
- Fast, accurate and easy to set
- Easy-to-read laser marked scales
- Flex Head pivots 15 degrees in both directions
- Rugged for Industrial use
- Accuracy: $\pm 4\%$ CW $\pm 6\%$ CCW of indicated value, CW, from 20% to 100% of full scale
- Meets or exceeds ASME B107.14-2004, ISO 6789 standards
- Individually serialized with matching certificate of calibration traceable to N.I.S.T.



FLEX-HEAD MICROMETER ADJUSTABLE TORQUE WRENCH

Product Code	Torque Range	Sq. Drive	Incr.	A In.	B In.	C In.	D In.	Wt. Lbs.
802MFRFMHSS	10-80 ft. lb.	3/8"	0.5	16.60	1.25	1.15	0.90	2.500

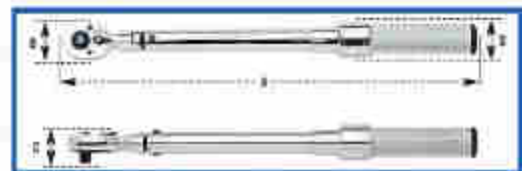



CDI TORQUE PACK PRESET WRENCHES

CDI's Torque Pack for the Professional Tire Installer

Features

- Covers all automotive and light truck applications
- Color coding matches common torque sticks
- Rubber Boot cover on head protects expensive wheels
- One way ratchet prevents damage to torque wrench
- Easy to read torque values printed on each wrench
- Increased productivity by reducing adjustment time

MODEL PTWS-2-CDI INCLUDES:

- 5 Preset Color Coded Torque Wrenches
65 ft. lbs., 80 ft. lbs., 100 ft. lbs., 120 ft.lbs., 140 ft. lbs.
- 1 Micrometer Adjustable Torque Wrench
50 - 250 ft. lbs.
- 6 Deep Wall Sockets
3/4", 13/16", 7/8", 17 mm, 19 mm and 21 mm
- 1 Socket Extension Bar
1/2" X 6 Inch
- 1 Color coordinated lug nut torque chart
- 1 Wall mounted blow moulded rack



CDI TPMS-4VC

CDI's TPMS for the Professional Tire Installer

Features

- Prevents damage to costly componets
- No guessing, DO IT RIGHT the FIRST time
- Valve core tool prevents leaks and stripping
- Specifically designed to be used as a core remover and precise installer for TPMS tire valve to eliminate risk of damaging expensive TPMS sensors
- Preset to 4 ft. lb. to prevent over or undertorquing
- Preset torque setting also helps prevent valve core leaks that lead to low tire pressure and TPMS alerts

INTERCHANGEABLE HEAD TORQUE WRENCHES

Features

- Interchangeable heads permit ratcheting, fixed, or open end torquing capability with adjustable torque wrench bodies.
- A push of the locking pin provides quick-change action, with a wide range of head styles to choose from.
- Micrometer Type Adjustment-ensures fast, accurate settings and changes.
- *Part Number 800NMIMH has Dual Pin Release for added strength



INTERCHANGEABLE HEAD TORQUE WRENCHES - DUAL SCALE

Product Code	Shank Size	Nm Range	Incr.	English Range
50NMIMH	J	10 - 50	0.5	7.4 - 44.2
100NMIMH	J	20 - 100	0.5	14.8 - 73.8
200NMIMH	Y	40 - 200	2	29.5 - 147.5
350NMIMH	X	70 - 350	2	44.3 - 250.8
800NMIMH*	Z	150 - 800	5	110.6 - 590

INTERCHANGEABLE HEAD TORQUE WRENCHES - SINGLE SCALE

Product Code	Shank Size	English Range	Incr.
75MFIMHSS	J	5 - 75	0.5
150MFIMHSS	Y	20 - 150	1
250MFIMHSS	Y	30 - 250	1



SINGLE SETTING TORQUE WRENCHES

Single setting torque wrenches are designed for use on production lines and other applications where a specific torque is required for repetitive operations.

Features

- Factory Pre-Set models are set at the factory to the customer's specified torque setting, and are furnished with a Certificate of Calibration.
- Please specify desired torque setting when order is placed.
- Featuring a durable, non-slip cushion grip
- Uses universal round shank heads
- Audible click and feel impulse torque control mechanism
- Tamper proof torque setting for production line use
- Accuracy: $\pm 4\%$ of indicated value, in direction of torque indicator, from 20% to 100% of full scale
- Meets or exceeds ASME B107.14-2004, ISO 6789

SINGLE SETTING TORQUE WRENCHES

Product Code Un-Set	Product Code Factory Pre-Set	English Range	Nm Range	Shank Size	A In.	B In.	C In.	D In.	Wt. Lbs.
5T-I	5T-I-SET	10 - 50 in. lb.	1.1 - 5.6	J	6.5	0.63	0.61	1	0.35
10T-I	10T-I-SET	50 - 250 in. lb.	5.6 - 28	J	10	0.63	0.61	1	0.55
10ST-I	10ST-I-SET	60 - 300 in. lb.	6.8 - 34	J	6.2	0.68	0.86	1.4	0.75
50T-I	50T-I-SET	15 - 75 ft. lb.	20 - 102	J	11	0.68	0.96	1.4	1.4
100T-I	100T-I-SET	30 - 150 ft. lb.	41 - 203	Y	19.5	0.94	0.96	1.4	2.3
200T-I	200T-I-SET	40 - 200 ft. lb.	54 - 271	Y	23.5	0.94	0.86	1.4	2.6
300T-I	300T-I-SET	100 - 300 ft. lb.	135 - 406	X	27.7	1.12	1	1.4	3.9
600T-I	600T-I-SET	120 - 600 ft. lb.	162 - 814	Z	55	1.5	1.25	1.25	10.45



RATCHETING SQUARE DRIVE HEADS - SAE



Z Shank Dual Pins



Square Drive (Inches)	J (0.425")	Max Torque Ft. Lbs.	Y (0.560")	Max Torque Ft. Lbs.	X (0.735")	Max Torque Ft. Lbs.	Z (0.990")	Max Torque Ft. Lbs.	Z Dual Pins	Max Torque Ft. Lbs.
1/4	TCQJD8A-72	60								
3/8	TCQJD12A-80	60	TCQYD12A-80	100						
1/2	TCQJD16A	60	TCQYD16A	240	TCQXD16A	240				
3/4					TCQXD24A	240	TCQZD24B	700	TCQZD24BDP	700
1					TCQXD32A	240	TCQZD32B	700	TCQZD32BDP	700

FIXED SQUARE DRIVE HEADS - SAE



Z Shank Dual Pins



Square Drive (Inches)	J (0.425")	Max Torque Ft. Lbs.	Y (0.560")	Max Torque Ft. Lbs.	X (0.735")	Max Torque Ft. Lbs.	Z (0.990")	Max Torque Ft. Lbs.	Z Dual Pins	Max Torque Ft. Lbs.
1/4	TCQJSD8A	60								
3/8	TCQJSD12A	60	TCQYSD12A	100						
1/2	TCQJSD16A	60	TCQYSD16A	240	TCQXSD16A	240				
3/4					TCQXSD24A	240	TCQZSD24A	480	TCQZSD24ADP	480
1					TCQXSD32A	240	TCQZSD32A	480		

OPEN END HEADS - SAE



Z Shank Dual Pins



Square Drive (Inches)	J (0.425")	Max Torque Ft. Lbs.	Y (0.560")	Max Torque Ft. Lbs.	X (0.735")	Max Torque Ft. Lbs.	Z (0.990")	Max Torque Ft. Lbs.	Z Dual Pins	Max Torque Ft. Lbs.
1/4	TCQJO8A	5								
9/32	TCQJO9A	7								
5/16	TCQJO10A	9								
3/8	TCQJO12A	18								
7/16	TCQJO14A	26								
1/2	TCQJO16A	34								
9/16	TCQJO18A	58	TCQYO18A	58						
5/8	TCQJO20A	60	TCQYO20A	70						
11/16	TCQJO22A	60	TCQYO22A	99						
3/4	TCQJO24A	60	TCQYO24A	125	TCQXO24A	125				
13/16	TCQJO26A	60	TCQYO26A	160	TCQXO26A	164				
7/8	TCQJO28A	60	TCQYO28A	160	TCQXO28A	193				
15/16	TCQJO30A	60	TCQYO30A	160	TCQXO30A	200				
1	TCQJO32A	60	TCQYO32A	160	TCQXO32A	240	TCQZO32A	298	TCQZO32ADP	480
1 1/16	TCQJO34A	60	TCQYO34A	160	TCQXO34A	240	TCQZO34A	321	TCQZO34ADP	480
1 1/8	TCQJO36A	60	TCQYO36A	160	TCQXO36A	240	TCQZO36A	367	TCQZO36ADP	480
1 3/16			TCQYO38A	160	TCQXO38A	240	TCQZO38A	433	TCQZO38ADP	480
1 1/4	TCQJO40A	60	TCQYO40A	160	TCQXO40A	240	TCQZO40A	480	TCQZO40ADP	480
1 5/16			TCQYO42A	160	TCQXO42A	240	TCQZO42A	480	TCQZO42ADP	480
1 3/8	TCQJO44A	60	TCQYO44A	160	TCQXO44A	240	TCQZO44A	480	TCQZO44ADP	480
1 7/16			TCQYO46A	160	TCQXO46A	240	TCQZO46A	480	TCQZO46ADP	480
1 1/2	TCQJO48A	60	TCQYO48A	160	TCQXO48A	240	TCQZO48A	480	TCQZO48ADP	480
1 9/16			TCQYO50A	160	TCQXO50A	240	TCQZO50A	480	TCQZO50ADP	480
1 5/8	TCQJO52A	60	TCQYO52A	160	TCQXO52A	240	TCQZO52A	480	TCQZO52ADP	480
1 11/16					TCQXO54A	240	TCQZO54A	480	TCQZO54ADP	480
1 3/4			TCQYO56A	240	TCQXO56A	240	TCQZO56A	480	TCQZO56ADP	480
1 13/16					TCQXO58A	240	TCQZO58A	480	TCQZO58ADP	480
1 7/8			TCQYO60A	240	TCQXO60A	240	TCQZO60A	480	TCQZO60ADP	480
2					TCQXO64A	240	TCQZO64A	480	TCQZO64ADP	480
2 1/16							TCQZO66A	480	TCQZO66ADP	480
2 1/8							TCQZO68A	480	TCQZO68ADP	480
2 1/4			TCQY072	160			TCQZO72A	480	TCQZO72ADP	480
2 3/8									TCQZO76ADP	480
2 1/2			TCQY080	160			TCQZO80A	480	TCQZO80ADP	480
2 3/4							TCQZO88A	480		
3							TCQZO96A	480		

Shank Size Diameters	
J =	0.425
Y =	0.560
X =	0.735
Z =	0.990

Center of fastener to retaining pin:

TCQJ Series - 2.50"

TCQY Series - 3.00"

TCQX Series - 4.50"

TCQZ Series - 5.75"



OPEN END HEADS - METRIC

Square Drive (mm)	J (0.425")	Max Torque Ft. Lbs.	Y (0.560")	Max Torque Ft. Lbs.	X (0.735")	Max Torque Ft. Lbs.	Z (0.990")	Max Torque Ft. Lbs.	Z Dual Pins	Max Torque Ft. Lbs.
6	TCQJOM6A	5								
7	TCQJOM7A	6								
8	TCQJOM8A	10								
9	TCQJOM9A	14								
10	TCQJOM10A	22								
11	TCQJOM11A	33								
12	TCQJOM12A	36								
13	TCQJOM13A	41								
14	TCQJOM14A	55	TCQYOM14A	55						
15	TCQJOM15A	60	TCQYOM15A	74						
16	TCQJOM16A	60	TCQYOM16A	88						
17	TCQJOM17A	60	TCQYOM17A	103	TCQXOM17A	103				
18	TCQJOM18A	60	TCQYOM18A	115	TCQXOM18A	115				
19	TCQJOM19A	60	TCQYOM19A	138	TCQXOM19A	138				
20	TCQJOM20A	60	TCQYOM20A	160	TCQXOM20A	160				
21	TCQJOM21A	60	TCQYOM21A	160	TCQXOM21A	180				
22	TCQJOM22A	60	TCQYOM22A	160	TCQXOM22A	206				
23	TCQJOM23A	60	TCQYOM23A	160	TCQXOM23A	229				
24	TCQJOM24A	60	TCQYOM24A	160	TCQXOM24A	240	TCQZOM24A	248	TCQZOM24ADP	250
25	TCQJOM25A	60	TCQYOM25A	160	TCQXOM25A	240				
26	TCQJOM26A	60	TCQYOM26A	160	TCQXOM26A	240				
27	TCQJOM27A	60	TCQYOM27A	160	TCQXOM27A	240	TCQZOM27A	319	TCQZOM27ADP	319
29			TCQYOM29A	160	TCQXOM29A	240				
30			TCQYOM30A	160	TCQXOM30A	240	TCQZOM30A	413	TCQZOM30ADP	413
32			TCQYOM32A	160	TCQXOM32A	240	TCQZOM32A	480	TCQZOM32ADP	480
34			TCQYOM34A	160	TCQXOM34A	240			TCQZOM34ADP	480
36			TCQYOM36A	160	TCQXOM36A	240	TCQZOM36A	480	TCQZOM36ADP	480
38									TCQZOM38ADP	480
41					TCQXOM41A	240			TCQZOM41ADP	480
46									TCQZOM46ADP	480
50							TCQZOM50A	480	TCQZOM50ADP	480
55							TCQZOM55A	480	TCQZOM55ADP	480
60									TCQZOM60ADP	480
65									TCQZOM65ADP	480
70									TCQZOM70ADP	480



Z Shank Dual Pins



RATCHETING OPEN END HEADS - SAE

Square Drive (Inches)	J (0.425")	Max Torque Ft. Lbs.
3/8	TCQJRO12A	11
7/16	TCQJRO14A	16
1/2	TCQJRO16A	20
9/16	TCQJRO18A	35
5/8	TCQJRO20A	40



RATCHETING OPEN END HEADS - METRIC

Square Drive (mm)	J (0.425")	Max Torque Ft. Lbs.
12	TCQJROM12A	21
13	TCQJROM14A	25
14	TCQJROM16A	36
15	TCQJROM18A	45
17	TCQJROM20A	50





12-POINT BOX END HEADS - SAE



Z Shank Dual Pins

Square Drive (Inches)	J (0.425")	Max Torque Ft. Lbs.	Y (0.560")	Max Torque Ft. Lbs.	X (0.735")	Max Torque Ft. Lbs.	Z (0.990")	Max Torque Ft. Lbs.	Z Dual Pins	Max Torque Ft. Lbs.
1/4	TCQJX8A	18								
9/32	TCQJX9A	41								
5/16	TCQJX10A	41								
3/8	TCQJX12A	60								
7/16	TCQJX14A	60								
1/2	TCQJX16A	60	TCQYX16A	75						
9/16	TCQJX18A	60	TCQYX18A	112						
5/8	TCQJX20A	60	TCQYX20A	160	TCQXX20A	171				
11/16	TCQJX22A	60	TCQYX22A	160	TCQXX22A	200				
3/4	TCQJX24A	60	TCQYX24A	160	TCQXX24A	219				
13/16	TCQJX26A	60	TCQYX26A	160	TCQXX26A	240	TCQZX26A	275	TCQZX26ADP	275
7/8	TCQJX28A	60	TCQYX28A	160	TCQXX28A	240				
15/16	TCQJX30A	60	TCQYX30A	160	TCQXX30A	240	TCQZX30A	300		
1	TCQJX32A	60	TCQYX32A	160	TCQXX32A	240				
1 1/16	TCQJX34A	60	TCQYX34A	160	TCQXX34A	240	TCQZX34A	480	TCQZX34ADP	300
1 1/8			TCQYX36A	160	TCQXX36A	240	TCQZX36A	480	TCQZX36ADP	480
1 3/16			TCQYX38A	160	TCQXX38A	240	TCQZX38A	480	TCQZX38ADP	480
1 1/4			TCQYX40A	160	TCQXX40A	240	TCQZX40A	480	TCQZX40ADP	480
1 5/16			TCQYX42A	160	TCQXX42A	240	TCQZX42A	480	TCQZX42ADP	480
1 3/8					TCQXX44A	240	TCQZX44A	480		
1 7/16			TCQYX46A	160	TCQXX46A	240	TCQZX46A	480	TCQZX46ADP	480
1 1/2			TCQYX48A	160	TCQXX48A	240	TCQZX48A	480	TCQZX48ADP	480
1 9/16			TCQYX50A	160	TCQXX50A	240	TCQZX50A	480	TCQZX50ADP	480
1 5/8			TCQYX52A	160	TCQXX52A	240	TCQZX52A	480	TCQZX52ADP	480
1 11/16					TCQXX54A	240	TCQZX54A	480	TCQZX54ADP	480
1 3/4					TCQXX56A	240	TCQZX56A	480	TCQZX56ADP	480
1 13/16					TCQXX58A	240	TCQZX58A	480	TCQZX58ADP	480
1 7/8					TCQXX60A	240	TCQZX60A	480	TCQZX60ADP	480
2					TCQXX64A	240	TCQZX64A	480	TCQZX64ADP	480
2 1/16							TCQZX66A	480	TCQZX66ADP	480
2 1/8							TCQZX68A	480	TCQZX68ADP	480
2 3/16									TCQZX70ADP	480
2 1/4							TCQZX72A	480	TCQZX72ADP	480
2 3/8									TCQZX76ADP	480
2 1/2							TCQZX80A	480	TCQZX80ADP	480

12-POINT BOX END 0° OFFSET - SAE



Square Drive (Inches)	J (0.425")	Max Torque Ft. Lbs.	Y (0.560")	Max Torque Ft. Lbs.
3/8	TCQJXD12A	60		
7/16	TCQJXD14A	60		
1/2	TCQJXD16A	60		
9/16	TCQJXD18A	60		
5/8			TCQYXD20A	160
11/16	TCQJXD22A	60	TCQYXD22A	160
3/4	TCQJXD24A	60	TCQYXD24A	160
7/8	TCQJXD28A	60		
15/16	TCQJXD30A	60	TCQYXD30A	160
1	TCQJXD32A	60		





12-POINT BOX END 0° OFFSET - METRIC

Square Drive (mm)	J (0.425")	Max Torque Ft. Lbs.	Y (0.560")	Max Torque Ft. Lbs.	X (0.735")	Max Torque Ft. Lbs.	Z (0.990")	Max Torque Ft. Lbs.	Z Dual Pins	Max Torque Ft. Lbs.
6	TCQJXM6A	15								
7	TCQJXM7A	20								
8	TCQJXM8A	22								
9	TCQJXM9A	30								
10	TCQJXM10A	53								
11	TCQJXM11A	59								
12	TCQJXM12A	60								
13	TCQJXM13A	60	TCQYXM13A	75						
14	TCQJXM14A	60	TCQYXM14A	117						
15	TCQJXM15A	60	TCQYXM15A	148						
16	TCQJXM16A	60	TCQYXM16A	160	TCQXXM16A	183				
17	TCQJXM17A	60	TCQYXM17A	160	TCQXXM17A	197				
18	TCQJXM18A	60	TCQYXM18A	160	TCQXXM18A	224				
19	TCQJXM19A	60	TCQYXM19A	160	TCQXXM19A	238				
20	TCQJXM20A	60	TCQYXM20A	160	TCQXXM20A	240				
21	TCQJXM21A	60	TCQYXM21A	160	TCQXXM21A	240				
22	TCQJXM22A	60	TCQYXM22A	160	TCQXXM22A	240				
23	TCQJXM23A	60	TCQYXM23A	160	TCQXXM23A	240				
24	TCQJXM24A	60	TCQYXM24A	160	TCQXXM24A	240	TCQZXM24A	375	TCQZXM24ADP	375
25	TCQJXM25A	60	TCQYXM25A	160	TCQXXM25A	240	TCQZXM25A	413		
26	TCQJXM26A	60	TCQYXM26A	160	TCQXXM26A	240	TCQZXM26A	448		
27	TCQJXM27A	60	TCQYXM27A	160	TCQXXM27A	240	TCQZXM27A	480	TCQZXM27ADP	480
29			TCQYXM29A	160	TCQXXM29A	240	TCQZXM29A	480		
30			TCQYXM30A	160	TCQXXM30A	240	TCQZXM30A	480	TCQZXM30ADP	480
32			TCQYXM32A	160	TCQXXM32A	240	TCQZXM32A	480	TCQZXM32ADP	480
34			TCQYXM34A	160	TCQXXM34A	240	TCQZXM34A	480	TCQZXM34ADP	480
36			TCQYXM36A	160	TCQXXM36A	240	TCQZXM36A	480	TCQZXM36ADP	480
41									TCQZXM41ADP	480
46									TCQZXM46ADP	480
50									TCQZXM50ADP	480
55									TCQZXM55ADP	480
60									TCQZXM60ADP	480



Z Shank Dual Pins

12 POINT RATCHET WRENCH HEADS - METRIC

Square Drive (mm)	J (0.425")	Max Torque Ft. Lbs.	Y (0.560")	Max Torque Ft. Lbs.
16	TCQJBOERM16	60		
18	TCQJBOERM18	60	TCQYBOERM18	160
24			TCQYBOERM24	160



12 POINT RATCHET WRENCH HEADS - SAE

Square Drive (Inches)	J (0.425")	Max Torque Ft. Lbs.	Y (0.560")	Max Torque Ft. Lbs.
3/8	TCQJBOER12	60		
7/16	TCQJBOER14	60		
1/2	TCQJBOER16	60		
9/16	TCQJBOER18	60	TCQYBOER18	112
5/8	TCQJBOER20	60	TCQYBOER20	160
11/16			TCQYBOER22	160
3/4	TCQJBOER24	60	TCQYBOER24	160



12-POINT BOX END 10° OFFSET - SAE



Square Drive (Inches)	J (0.425")	Max Torque Ft. Lbs.	Y (0.560")	Max Torque Ft. Lbs.	X (0.735")	Max Torque Ft. Lbs.
1/2	TCQJXB16A	60				
9/16	TCQJXB18A	60				
5/8	TCQJXB20A	60	TCQYXB20A	79		
11/16	TCQJXB22A	60				
3/4	TCQJXB24A	60	TCQYXB24A	160		
7/8			TCQYXB28A	133		
15/16			TCQYXB30A	160		
1			TCQYXB32A	160		
1 1/8			TCQYXB36A	160		
1 3/8					TCQXXB44A	240
1 1/2					TCQXXB48A	240

12-POINT BOX END 10° OFFSET - METRIC



Square Drive (mm)	J (0.425")	Max Torque Ft. Lbs.	Y (0.560")	Max Torque Ft. Lbs.
11mm	TCQJXBM11A	59		
12mm	TCQJXBM12A	60		
13mm	TCQJXBM13A	60		
14mm	TCQJXBM14A	60		
16mm	TCQJXBM16A	60		
18mm	TCQJXBM18A	60	TCQYXBM18A	160
19mm	TCQJXBM19	60		
24mm			TCQYXBM24A	160
28mm			TCQYXBM28A	160

6-POINT BOX END 10° OFFSET - METRIC



Square Drive (mm)	Y (0.560")	Max Torque Ft. Lbs.
18	TCQYSBXM18A	160
24	TCQYSBXM24A	160

12 POINT FLARE NUT HEADS - SAE



Square Drive (Inches)	J (0.425")	Max Torque Ft. Lbs.	Y (0.560")	Max Torque Ft. Lbs.
9/16	TCQJRX18A	60	TCQYRX18A	67
5/8	TCQJRX20A	60	TCQYRX20A	79
11/16	TCQJRX22A	60	TCQYRX22A	92
3/4	TCQJRX24A	60	TCQYRX24A	104
13/16	TCQJRX26A	60	TCQYRX26A	117
7/8	TCQJRX28A	60	TCQYRX28A	133
15/16	TCQJRX30A	60	TCQYRX30A	146
1	TCQJRX32A	60	TCQYRX32A	158
1 1/16	TCQJRX34A	60	TCQYRX34A	160
1 1/8			TCQYRX36A	160
1 3/16			TCQYRX38A	160
1 1/4			TCQYRX40A	160



6 POINT FLARE NUT HEADS - METRIC

Square Drive (mm)	J (0.425")	Max Torque Ft. Lbs.	Y (0.560")	Max Torque Ft. Lbs.
8	TCQJRXS8A	17		
9	TCQJRXS9A	25		
10	TCQJRXS10A	33		
11	TCQJRXS11A	42		
12	TCQJRXS12A	50		
13	TCQJRXS13A	58		
14	TCQJRXS14A	60		
15	TCQJRXS15A	60	TCQYRXSM15A	71
16	TCQJRXS16A	60	TCQYRXSM16A	75
17	TCQJRXS17A	60	TCQYRXSM17A	83
18	TCQJRXS18A	60	TCQYRXSM18A	94
19	TCQJRXS19A	60	TCQYRXSM19A	104
20	TCQJRXS20A	60	TCQYRXSM20A	113
21			TCQYRXSM21A	113



6 POINT FLARE NUT HEADS - SAE

Square Drive (Inches)	J (0.425")	Max Torque Ft. Lbs.	Y (0.560")	Max Torque Ft. Lbs.
1/4	TCQJRXS8A	6		
5/16	TCQJRXS10A	17		
3/8	TCQJRXS12A	29		
7/16	TCQJRXS14A	42		
1/2	TCQJRXS16A	54		
9/16	TCQJRXS18A	60		
5/8	TCQJRXS20A	60	TCQYRXS20A	74
11/16	TCQJRXS22A	60	TCQYRXS22A	92
3/4	TCQJRXS24A	60	TCQYRXS24A	104
13/16	TCQJRXS26A	60	TCQYRXS26A	117
7/8	TCQJRXS28A	60	TCQYRXS28A	133
15/16	TCQJRXS30A	60	TCQYRXS30A	146
1	TCQJRXS32A	60	TCQYRXS32A	158
1 1/8			TCQYRXS36A	160



Shank Size Diameters
J = 0.425
Y = 0.560
X = 0.735
Z = 0.990



OPEN END THIN HEADS - SAE



Square Drive (Inches)	J (0.425")	Max Torque Ft. Lbs.	Y (0.560")	Max Torque Ft. Lbs.
11/16	TCQJ022ARTH60	60		
1	TCQJ032ARTH	60		
1 1/16	TCQJ034ARTH	60		
1 1/8	TCQJ036ARTH	60		
1 3/16	TCQJ038ARTH	60		
1 1/4	TCQJ040ARTH	60		
1 3/8	TCQJ044ARTH	60		
1 1/2	TCQJ048ARTH	60		
1 9/16	TCQJ050ARTH	60		
1 5/8	TCQJ052ARTH	60	TCQY052ARTH	160
1 3/4	TCQJ056ARTH	60	TCQY056ARTH	160
1 7/8	TCQJ060ARTH	60	TCQY060ARTH	160
2	TCQJ064ARTH	60	TCQY064ARTH	160
2 1/16	TCQJ066ARTH	60		
2 1/8			TCQY068ARTH	160
2 1/4			TCQY072ARTH	160
2 11/16	TCQJ086ARTH	60		

RATCHETING FLARE NUT HEAD



Square Drive (Inches)	J (0.425")	Y (0.560")	X (0.735")
9/16	TCRTWH36J		
5/8	TCRTWH40H		
11/16	TCRTWH44J		
3/4		TCRTWH48Y	
13/16	TCRTWH52J		
7/8		TCRTWH56Y	
15/16		TCRTWH60Y	
1		TCRTWH64Y	
1 1/8		TCRTWH72Y	
1 1/4		TCRTWH80Y	
1 3/8		TCRTWH88Y	
1 1/2			TCRTWH96X
16mm	TCRTWHM16J		
1 5/8		TCRTWH104Y	
1 7/8		TCRTWH120Y	

ADAPTORS



Product Code	Descriptions
TCQJ-Y	J Male to Y Female
TCQXY	X Male to Y Female
TCQY-X	Y Male to X Female
TCQZ-X	Z Male to X Female
TCQZD24A-1	Z Male to 3/4" Ratchet
TCQZD32A-1	Z Male to 1" Ratchet



WHY IS TORQUE CRITICAL?

KNOWLEDGE IS KEY

These illustrations explain why torque instruments are critical to the application of the correct amount of load or tension to threaded fasteners. Original Equipment Manufacturers specify the amount of torque that is applied to fasteners to ensure they maintain the proper load within operating conditions.

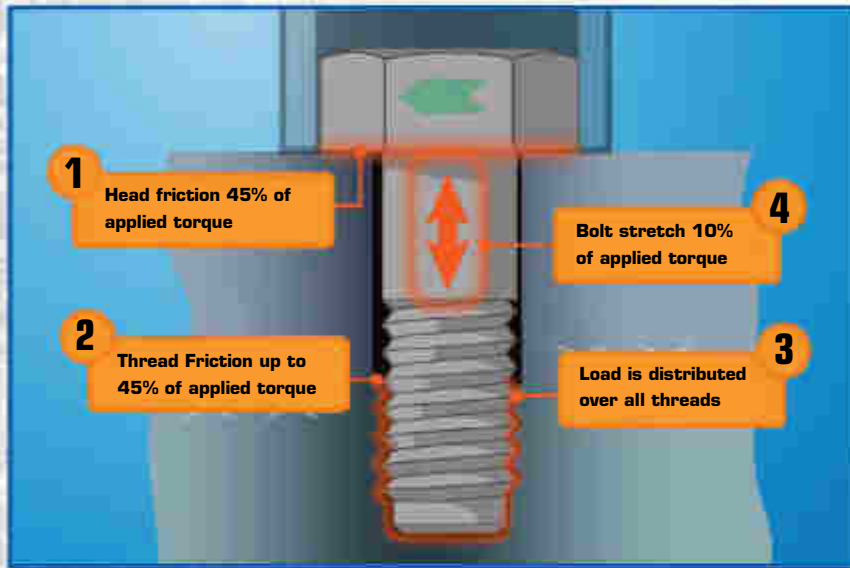

A properly torqued fastener will remain tight during all loads and vibration. A poorly torqued fastener can fail quickly from fatigue creating a potentially unsafe situation. Many technicians don't realize the importance of tightening a fastener to a specified torque value or literally what is actually occurring with the fastener while torque is being applied.

A fastener that is stretched (preloaded) to its designed level of residual stress will resist failure for the given cycle load and the maximum number of fatigue cycles it was designed for. It will also provide maximum resistance to loosening from vibration.

A fastener installed in an under-stressed condition will loosen under load and ultimately fail by loss of clamping force. A fastener that is over tightened will fail during installation or fail prematurely during under cycle stress.

CDI Torque Products provides professional technicians the largest selection of high-quality torque tools in the market today. Whether looking for a traditional click-type wrench or something cutting edge like the Computorq 3 wrench, CDI Torque Products has all of the torque wrench, sizes and styles to fill your needs. Our products have earned a reputation for superior performance and reliability in shops and factories worldwide that deliver.

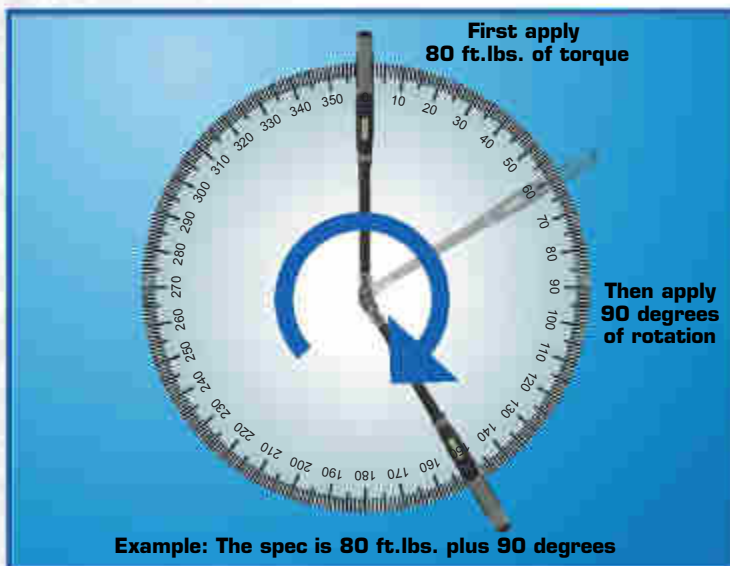

TORQUE WRENCH SAFETY

These precautions should always be taken when using any torque wrench to avoid possible injury:

- Read instruction manual completely before using torque wrench.
- Safety glasses or goggles should be worn at all times when using any hand tool.
- Always pull, DO NOT PUSH, to apply torque and adjust your stance to prevent a fall.
- A “cheater bar” should NEVER be used on a torque wrench to apply excess leverage.
- Do not use with sockets or fasteners showing wear or cracks.
- Ratchet mechanism may slip or break if dirty, mismatched or worn parts are used.
- Make sure direction lever is fully engaged

TORQUE WRENCH USAGE

- All mechanical torque wrenches are calibrated from 20% to 100% of full scale, therefore, they should never be used below or above those limits
- To determine which torque wrench capacity is best suited for an application, many factors must be considered. However, as a recommendation, use a torque wrench in the middle 50% of the overall capacity of the tool. This will result in longer tool life, ease of use for the operator and increased accuracy from “clicker” type torque wrenches
- Always grasp handle firmly in the center of the grip
- Approach final torque slowly and evenly
- Stop pulling wrench immediately when target torque is reached
- Never use a torque wrench to break fasteners loose
- Should be cleaned and stored properly
- Should always be stored at it’s lowest torque setting
- Wrenches should be re-calibrated if dropped. Should never be used in excess of it’s capacity
- Torque wrenches should be “exercised” a minimum of three times at 100% of full scale before use
- The wrench selected should be calibrated in the same torque units that are specified
- Use of a “cheater bar” will result in an inaccurate reading and can possibly damage the wrench
- Torque wrenches will last longer if reasonable care is taken. Always unwind handle to the lowest setting after each use. Do not attempt to lubricate the internal torque mechanism. Clean torque wrench by wiping, do not immerse. The wrench should be sent to a qualified calibration lab once every year or every 5000 cycles for re-calibration

COMMON TORQUE ABBREVIATIONS

Foot Pounds – ft. lbs.
Inch Pounds – in. lbs.
Inch Ounces – in. ozs.
Newton Meter – Nm
Centi-Newton Meter – cNm
Meter Kilogram – Mkg

**EASY-TO-USE TORQUE
CONVERSION TABLE**

To Convert From	To	Multiply by
in. oz.	in. lb.	0.0625
in. lb.	in.oz.	16
in. lb.	ft.lb.	0.08333
in. lb.	cmkg	1.1519
in. lb.	mkg	0.011519
in. lb.	Nm	0.113
in. lb.	dNm	1.13
ft. lb.	in. lb.	12
ft. lb.	mkg	0.1382
ft. lb.	Nm	1.356
dNm	in. lb.	0.885
dNm	Nm	0.10
Nm	dNm	10
Nm	cmkg	10.2
Nm	mkg	0.102
Nm	in. lb.	8.85
Nm	ft. lb.	0.7376
cmkg	in. lb.	0.8681
cmkg	Nm	0.09807
mkg	in. lb.	86.81
mkg	ft. lb.	7.236
mkg	Nm	9.807

REPAIR & SERVICE CENTER

For over 30 years the CDI Repair and Service Center has been providing quality torque tool repair and calibration services performed by highly trained technicians. CDI Torque Products is a premier torque wrench and torque calibration equipment manufacturer that has been ISO 9001 certified since 1998. Mechanical torque tools and electronic torque equipment are designed, built and serviced in our City of Industry, California facility. CDI's mechanical and electronic torque tools are repaired and calibrated with N.I.S.T. (National Institute of Standards and Technology) traceable calibration equipment. CDI Torque Products meets or exceeds ASME and ISO standards. All of CDI's primary torque wrench calibration equipment used in manufacturing and repair are calibrated on a monthly basis — that's twelve times a year!!

In addition to repair and calibration services, CDI offers training in several areas. Technical training is available at our facility for any CDI manufactured torque calibration system. Training in mechanical and electronic torque wrench repair, torque theory, torque basics and safety training is also available.

All electronic torque checking, testing and calibration equipment sent to CDI for servicing is returned to factory standards and a certificate of calibration is provided at no extra cost. Rely on the CDI Repair and Service Center to do the job right the first time.



MECHANICAL AND ELECTRONIC TORQUE PRODUCTS FULL 12-MONTH WARRANTY

SNAP-ON INDUSTRIAL BRANDS WARRANTS TO THE ORIGINAL PURCHASER OF TORQUE PRODUCTS THAT THE COMPANY'S TORQUE PRODUCTS ARE FREE FROM DEFECTS IN WORKMANSHIP AND MATERIALS. SNAP-ON INDUSTRIAL BRANDS will repair or replace torque products which fail to give satisfactory service due to defective workmanship or materials (excluding calibration) for 12 months from the date of original purchase. SNAP-ON INDUSTRIAL BRANDS warrants "initial, out of box calibration" of each new, unused torque product. Repair, replacement or recalibration shall be at the election and expense of SNAP-ON INDUSTRIAL BRANDS, and is your exclusive remedy in place of all other rights and remedies. Products must be returned with proof of purchase, freight prepaid, to a SNAP-ON INDUSTRIAL BRANDS repair center for warranty service. SNAP-ON INDUSTRIAL BRANDS does not provide any warranty for products subjected to abnormal use. Abnormal use includes misuse, accident, modification, unreasonable use, neglect, lack of maintenance, or use after the tool is significantly worn.

"NO OTHER WARRANTIES, EXPRESS, IMPLIED OR STATUTORY, INCLUDING WITHOUT LIMITATION ANY IMPLIED WARRANTY OF MERCHANTABILITY OR FITNESS FOR A PARTICULAR PURPOSE, SHALL APPLY, AND ALL SUCH WARRANTIES ARE HEREBY EXPRESSLY EXCLUDED."

In no event shall Seller be liable to Buyer or anyone claiming through or against Buyer for any special, indirect or consequential damages (including, without limitation, lost profits, revenues, anticipated sales, business opportunities or goodwill; interruption of business; or loss of business information).



TCQJXM27A	36	TCQXX56A	35	TCQYOM18A	34	TCQYXB28A	37	TCQZ064ADP	33	TCQZX64ADP	35
TCQJXM6A	36	TCQXX58A	35	TCQYOM19A	34	TCQYXB30A	37	TCQZ066A	33	TCQZX66A	35
TCQJXM7A	36	TCQXX60A	35	TCQYOM20A	34	TCQYXB32A	37	TCQZ066ADP	33	TCQZX66ADP	35
TCQJXM8A	36	TCQXX64A	35	TCQYOM21A	34	TCQYXB36A	37	TCQZ068A	33	TCQZX68A	35
TCQJXM9A	36	TCQXXB44A	37	TCQYOM22A	34	TCQYXBM18A	37	TCQZ068ADP	33	TCQZX68ADP	35
TCQJ-Y	39	TCQXXB48A	37	TCQYOM23A	34	TCQYXBM24A	37	TCQZ072A	33	TCQZX70ADP	35
TCQXD16A	33	TCQXXM16A	36	TCQYOM24A	34	TCQYXD20A	35	TCQZ072ADP	33	TCQZX72A	35
TCQXD24A	33	TCQXXM16A	36	TCQYOM25A	34	TCQYXD22A	35	TCQZ076ADP	33	TCQZX72ADP	35
TCQXD32A	33	TCQXXM17A	36	TCQYOM26A	34	TCQYXD24A	35	TCQZ080A	33	TCQZX76ADP	35
TCQXO24A	33	TCQXXM18A	36	TCQYOM27A	34	TCQYXD30A	35	TCQZ080ADP	33	TCQZX80A	35
TCQXO26A	33	TCQXXM19A	36	TCQYOM29A	34	TCQYXM13A	36	TCQZ088A	33	TCQZX80ADP	35
TCQXO28A	33	TCQXXM20A	36	TCQYOM30A	34	TCQYXM14A	36	TCQZ096A	33	TCQZXM24A	36
TCQXO30A	33	TCQXXM21A	36	TCQYOM32A	34	TCQYXM15A	36	TCQZOM24A	34	TCQZXM24ADP	36
TCQXO32A	33	TCQXXM22A	36	TCQYOM34A	34	TCQYXM16A	36	TCQZOM24ADP	34	TCQZXM25A	36
TCQXO34A	33	TCQXXM23A	36	TCQYOM36A	34	TCQYXM17A	36	TCQZOM27A	34	TCQZXM26A	36
TCQXO36A	33	TCQXXM24A	36	TCQYRX18A	37	TCQYXM18A	36	TCQZOM27ADP	34	TCQZXM27A	36
TCQXO38A	33	TCQXXM25A	36	TCQYRX20A	37	TCQYXM19A	36	TCQZOM30A	34	TCQZXM27ADP	36
TCQXO40A	33	TCQXXM26A	36	TCQYRX22A	37	TCQYXM20A	36	TCQZOM30ADP	34	TCQZXM29A	36
TCQXO42A	33	TCQXXM26A	36	TCQYRX24A	37	TCQYXM21A	36	TCQZOM32A	34	TCQZXM30A	36
TCQXO44A	33	TCQXXM27A	36	TCQYRX26A	37	TCQYXM22A	36	TCQZOM32ADP	34	TCQZXM30ADP	36
TCQXO46A	33	TCQXXM29A	36	TCQYRX28A	37	TCQYXM23A	36	TCQZOM34ADP	34	TCQZXM32A	36
TCQXO48A	33	TCQXXM29A	36	TCQYRX30A	37	TCQYXM24A	36	TCQZOM36A	34	TCQZXM32ADP	36
TCQXO50A	33	TCQXXM30A	36	TCQYRX32A	37	TCQYXM25A	36	TCQZOM36ADP	34	TCQZXM34A	36
TCQXO52A	33	TCQXXM32A	36	TCQYRX34A	37	TCQYXM26A	36	TCQZOM38ADP	34	TCQZXM34ADP	36
TCQXO54A	33	TCQXXM34A	36	TCQYRX36A	37	TCQYXM27A	36	TCQZOM41ADP	34	TCQZXM36A	36
TCQXO56A	33	TCQXXM36A	36	TCQYRX38A	37	TCQYXM29A	36	TCQZOM46ADP	34	TCQZXM36ADP	36
TCQXO58A	33	TCQXY	39	TCQYRX40A	37	TCQYXM30A	36	TCQZOM50A	34	TCQZXM41ADP	36
TCQXO60A	33	TCQY052ARTH	39	TCQYRXS18A	38	TCQYXM32A	36	TCQZOM50ADP	34	TCQZXM46ADP	36
TCQXO64A	33	TCQY056ARTH	39	TCQYRXS20A	38	TCQYXM34A	36	TCQZOM55A	34	TCQZXM50ADP	36
TCQXOM17A	34	TCQY060ARTH	39	TCQYRXS22A	38	TCQYXM36A	36	TCQZOM55ADP	34	TCQZXM55ADP	36
TCQXOM18A	34	TCQY064ARTH	39	TCQYRXS24A	38	TCQZD24A-1	39	TCQZOM60ADP	34	TCQZXM60ADP	36
TCQXOM19A	34	TCQY068ARTH	39	TCQYRXS26A	38	TCQZD24B	33	TCQZOM65ADP	34	TCRTWH104Y	39
TCQXOM20A	34	TCQY072	33	TCQYRXS28A	38	TCQZD24BDP	33	TCQZOM70ADP	34	TCRTWH120Y	39
TCQXOM21A	34	TCQY072ARTH	39	TCQYRXS30A	38	TCQZD32A-1	39	TCQZSD24A	33	TCRTWH36J	39
TCQXOM22A	34	TCQY080	33	TCQYRXS32A	38	TCQZD32B	33	TCQZSD24ADP	33	TCRTWH40H	39
TCQXOM23A	34	TCQYBOER18	36	TCQYRXS36A	38	TCQZD32BDP	33	TCQZSD32A	33	TCRTWH44J	39
TCQXOM24A	34	TCQYBOER20	36	TCQYRXSM15A	38	TCQZO32A	33	TCQZ-X	39	TCRTWH48Y	39
TCQXOM25A	34	TCQYBOER22	36	TCQYRXSM16A	38	TCQZO32ADP	33	TCQZX26ADP	35	TCRTWH52J	39
TCQXOM26A	34	TCQYBOER24	36	TCQYRXSM17A	38	TCQZO34A	33	TCQZX30A	35	TCRTWH56Y	39
TCQXOM27A	34	TCQYBOERM18	36	TCQYRXSM18A	38	TCQZO34ADP	33	TCQZX34A	35	TCRTWH60Y	39
TCQXOM29A	34	TCQYBOERM24	36	TCQYRXSM19A	38	TCQZO36A	33	TCQZX34ADP	35	TCRTWH64Y	39
TCQXOM30A	34	TCQYD12A-80	33	TCQYRXSM20A	38	TCQZO36ADP	33	TCQZX36A	35	TCRTWH72Y	39
TCQXOM32A	34	TCQYD16A	33	TCQYRXSM21A	38	TCQZO38A	33	TCQZX36ADP	35	TCRTWH80Y	39
TCQXOM34A	34	TCQYO18A	33	TCQYYSBM18A	37	TCQZO38ADP	33	TCQZX38A	35	TCRTWH88Y	39
TCQXOM36A	34	TCQYO20A	33	TCQYYSBM24A	37	TCQZO40A	33	TCQZX38ADP	35	TCRTWH96X	39
TCQXOM41A	34	TCQYO22A	33	TCQYSD12A	33	TCQZO40ADP	33	TCQZX40A	35	TCRTWHM16J	39
TCQXSD16A	34	TCQYO24A	33	TCQYSD16A	33	TCQZO42A	33	TCQZX40ADP	35	TPMS-4VC	31
TCQXSD24A	34	TCQYO26A	33	TCQY-X	35	TCQZO42ADP	33	TCQZX42A	35	WSC-100CA	30
TCQXSD32A	34	TCQYO28A	33	TCQYX16A	35	TCQZO44A	33	TCQZX42ADP	35	WSC-250CA	30
TCQXX20A	35	TCQYO30A	33	TCQYX18A	35	TCQZO44ADP	33	TCQZX44A	35	WSC-400CA	30
TCQXX22A	35	TCQYO32A	33	TCQYX20A	35	TCQZO46A	33	TCQZX46A	35	WSC-50A	30
TCQXX24A	35	TCQYO34A	33	TCQYX22A	35	TCQZO46ADP	33	TCQZX46ADP	35	WSC-600CA	30
TCQXX26A	35	TCQYO36A	33	TCQYX24A	35	TCQZO48A	33	TCQZX48A	35		
TCQXX28A	35	TCQYO38A	33	TCQYX26A	35	TCQZO48ADP	33	TCQZX48ADP	35		
TCQXX30A	35	TCQYO40A	33	TCQYX28A	35	TCQZO50A	33	TCQZX50A	35		
TCQXX32A	35	TCQYO42A	33	TCQYX30A	35	TCQZO50ADP	33	TCQZX50ADP	35		
TCQXX34A	35	TCQYO44A	33	TCQYX32A	35	TCQZO52A	33	TCQZX52A	35		
TCQXX36A	35	TCQYO46A	33	TCQYX34A	35	TCQZO52ADP	33	TCQZX52ADP	35		
TCQXX38A	35	TCQYO48A	33	TCQYX38A	35	TCQZO54A	33	TCQZX54A	35		
TCQXX40A	35	TCQYO50A	33	TCQYX40A	35	TCQZO54ADP	33	TCQZX54ADP	35		
TCQXX42A	35	TCQYO52A	33	TCQYX42A	35	TCQZO56A	33	TCQZX56A	35		
TCQXX44A	35	TCQYO56A	33	TCQYX46A	35	TCQZO56ADP	33	TCQZX56ADP	35		
TCQXX46A	35	TCQYO60A	33	TCQYX48A	35	TCQZO58A	33	TCQZX58A	35		
TCQXX48A	35	TCQYOM14A	34	TCQYX50A	35	TCQZO58ADP	33	TCQZX58ADP	35		
TCQXX50A	35	TCQYOM15A	34	TCQYX52A	35	TCQZO60A	33	TCQZX60A	35		
TCQXX52A	35	TCQYOM16A	34	TCQYXB20A	37	TCQZO60ADP	33	TCQZX60ADP	35		
TCQXX54A	35	TCQYOM17A	34	TCQYXB24A	37	TCQZO64A	33	TCQZX64A	35		



WARRANTY STATIONS**United States****CDI Torque Products**

19220 San Jose Avenue
 City of Industry, CA 91748
 Phone: (626) 965-0668
 Fax: (626) 965-2410
 E-Mail: sales@cditorque.com
 Web Site: www.cditorque.com

Canada**Etaltech**

587 Adanac
 Beauport, Quebec
 Canada G1C 7G6
 Phone: 418.660.6081
 Fax: 418.660.6554
 E-Mail: etaltech@qc.aira.com

United States**Team Torque, Inc.**

A2LA Accredited to ISO 17025
 2910 E. Broadway #24
 Bismarck, ND 58501
 Phone: 701.223.4552 or 888.682.8675
 Fax: 701.222.3731
 E-Mail: service@teamtorque.com

Mexico**Arjessiger de Mexico, S.A. de C.V.**

PH: 01 (800) 522.22.65
 PH: 01 (800) 228.11.44
 PH: 011 (52) 553.91.06.65
 PH: 011 (52) 553.91.07.49
 FAX: 011 (52) 553.91.51.87
 E-Mail: ventas@arjessiger.com

United States**Angle Repair**

175 Angle Drive
 Beckley, WV 25801
 Phone: 304.253.5729
 Fax: 304.252.0481
 E-Mail: estimate@anglerepair.com

Standards & Specifications that Snap-on Specialty Tools manufactures to:

ISO 9001-2000 - Quality System
 Certified by Det Norske Veritas
 Certificate # CERT- 08745 - 2006 - AQ - HOU - ANAB

ISO 14001-2000 - Environmental System
 Certified by Det Norske Veritas
 Certificate # CERT- 02711 - 2006 - AE - HOU - ANAB

Occupational Health and Safety Assessment Series 18001: 1999 Edition - Safety System
 Certified by Det Norske Veritas
 Certificate # CERT- 03904 - 2006 -SOC - HOU - ANAB

ASME B107.28 - 2005 - Electronic Torque Instruments

ASME B107.29 - 2005 - Electronic Testers and Hand Torque Tools

US Air Force / Navy requirements for NSN # 6635 - 01 - 327 - 4461 - Multitest Calibration System (TFC2000 - 0 - 03)

CDI is a member of HTI and sits on the ASME Committee on Torque Instruments and NCSL International Metrology Group.

CDI TORQUE PRODUCTS®

19220 San Jose Avenue
City of Industry, CA 91748
Phone: (626) 965-0668
Fax: (626) 965-2410

SEE MANY MORE
TORQUE PRODUCTS AT
www.cditorque.com



© Copyright 2013,
Snap-on Incorporated.
All Rights Reserved.
2/13 Printed in USA